

PORCENTAJE DE DEVOLUCIÓN

BANCO 1	CNJ	76%	78%	80%	82%	84%	86%	86%	86%
	PV								
	AST								
	CAT AR AND	70%	73%	75%	78%	80%	82%	84%	86%
1	OFF	OFF	OFF	OFF	ON	ON	ON	ON	ON
2	OFF	OFF	ON	ON	OFF	OFF	ON	ON	ON
3	OFF	ON	OFF	ON	OFF	ON	OFF	ON	ON

PARA MÁS INFORMACIÓN
CONSULTE EL MANUAL
TÉCNICO



WORTE S.L.
Calle San Salvador 5
36204 VIGO

CONFIGURACIÓN HOPPERS

BANCO 2	5	6	7	8	Hopper1/ Hopper 2/ Hopper 3
	OFF	OFF	OFF	OFF	0,10 / 0,50 / 1,00 €
	OFF	OFF	ON	OFF	0,10 / 1,00 / 1,00 €
	OFF	ON	OFF	OFF	0,10 / 1,00 / 1,00 €
	OFF	ON	ON	OFF	0,20 / 1,00 / 1,00 €
	ON	OFF	OFF	OFF	0,10 / 0,50 / 2,00 €
	ON	OFF	ON	OFF	0,10 / 1,00 / 2,00 €
	ON	ON	OFF	OFF	0,10 / 1,00 / 2,00 €
ON	ON	ON	OFF	0,20 / 1,00 / 2,00 €	
Hopper1/ Hopper 2					
OFF	OFF	OFF	ON	0,10 / 0,50 €	
OFF	OFF	ON	ON	0,10 / 1,00 €	
OFF	ON	OFF	ON	0,10 / 1,00 €	
OFF	ON	ON	ON	0,10 / 2,00 €	
ON	OFF	OFF	ON	0,20 / 1,00 €	
ON	OFF	ON	ON	0,20 / 1,00 €	
ON	ON	OFF	ON	0,20 / 1,00 €	
ON	ON	ON	ON	0,20 / 2,00 €	



GUÍA
RÁPIDA

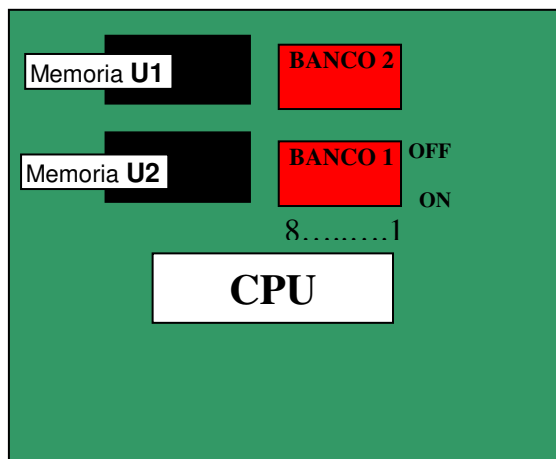

* La configuración afecta a:

- AST: Principado de Asturias
- PV: País Vasco
- CAT: Cataluña.
- AR: Aragón.
- AND: Andalucía
- CNJ: Resto de CCAA

BANCO 1	Nº	FUNCIÓN	ESTADO	Descripción
	1			
	2	%	ON/OFF	Ajuste del porcentaje
	3			
	4	No se utiliza (CNJ, AST, AR y AND)*	Cualquiera	
		Transferencia banco a créditos (PV y CAT)*	ON/OFF	Activa transferencia del banco a créditos.
	5	Retenciones automáticas	ON	Activadas
			OFF	Desactivadas
	6	Arqueo OFF	ON	Arqueo Desactivado
OFF			Arqueo Activado	
7	No se utiliza	Cualquiera		
8	Modo Demostración	ON	Activado	
		OFF	Desactivado	

BANCO 2	Nº	FUNCIÓN	ESTADO	Descripción
	1	Inhibe billete 10 €	ON	No acepta billete de 10 €
			OFF	Acepta billete de 10 €
	2	Inhibe billete 20 €	ON	No acepta billete de 20 €
			OFF	Acepta billete de 20 €
	3	Billete 10€ devuelve 2€ Billete 20€ devuelve 12€ (CNJ, PV, CAT, AR y AND)*	ON	Retorna 2 € al insertar 10 € Retorna 12€ al insertar 20 €
			OFF	10€ incrementa 50 créditos. 20€ incrementa 100 créditos
		No se utiliza (AST)*	Cualq	
	4	Doble/Nada 10c € (CNJ, PV, CAT, AR y AND)*	ON	Juego Doble/Nada activado
OFF			Juego Doble/Nada desactivado	
	No se utiliza (AST)*	Cualq		
5				
6	Hopper	ON/OFF	Configuración de hoppers.	
7				
8				