

 **HANTAREX**[®]

Electronic
Equipment
Manufacturer

colour
monitor

MTC 900

this is an HRS product :

**High
Reliability
Series**

INTRODUCTION

GB

The experience acquired by HANTAREX in Video Monitors has led to the development of the new MTC 900 HRS colour monitor which signals an important step in its program of continuous technological advancement. The initials HRS define the unit as one of a "High Reliability Series", obtained by means of the new HRS plant, using professional planning and production methods especially studied by Hantarex to improve reliability and to increase the life of its products.

The essential points permitting this achievement are:

1. Better component lay-out management, with particular attention paid to reliability. Wide margins on the operation of both active and passive components, with the elimination of all card contacts by using two horizontal modules.
2. Careful selection of components by a much stricter quality level (AQL).
3. Focus circuit obtained with a "Bleeder" resistance. i.e., by means of a resistance which shunts the focus voltage directly from the EHT socket. This is the latest European technical trend, already tried at production level, which practically eliminates damage caused to the monitor and logic boards during "flashover". This circuit has been designed to drive the new high definition picture tubes.
4. Use of a wide band integrated circuit in the video section manufactured especially for HANTAREX.
5. Protection circuit against the emission of X-rays according to international standards. Also the monitor switches-off, if the X-rays do exceed this level.
6. Dimensions of the chassis enable it to fit into any structure and it can hold c.r.t.'s from 14" to 26", 90° or 110° normal or high definition.

With these characteristics Hantarex is convinced to have provided, in the various versions of the MTC 900 HRS monitor, a product capable of meeting all the requirements of the colour video sector.

I

L'esperienza acquisita dalla Società HANTAREX nel campo dei monitor ha permesso la realizzazione del nuovo MTC 900 HRS che segna una ulteriore tappa nel costante aggiornamento tecnologico perseguito dalla Società nella realizzazione dei suoi prodotti.

La sigla HRS abbreviazione di High - Reliability - Series, qualifica e garantisce l'apparecchiatura come «serie di alta affidabilità» ottenuta mediante un HRS-PLANT cioè un piano di progettazione e produzione di tipo professionale particolarmente studiato per garantire la massima affidabilità del prodotto e quindi la sua durata nel tempo.

I punti essenziali che hanno permesso il raggiungimento di questo livello qualitativo sono:

1. *Progettazione elettronica e meccanica particolarmente curata nei riflessi dell'affidabilità ed eliminazione di tutti i contatti tra schede mediante l'uso di due soli moduli orizzontali.*
2. *Selezione accurata dei componenti mediante accettazione degli stessi secondo severi controlli di qualità (AQL).*
3. *Uso nella sezione video di un integrato a larga banda espressamente costruito per la società Hantarex che garantisce una ottima riproduzione dei caratteri alfa-numeric.*
4. *Circuito di focalizzazione ricavato con un BLEEDER, cioè tramite una resistenza che deriva la tensione di fuoco direttamente dalla ventosa di EAT. Questo circuito riduce drasticamente i danni derivati al monitor ed alle apparecchiature ad esso collegate dalle scariche del cinescopio.*
5. *Circuito di protezione contro l'emissione di raggi X a norme internazionali.*
6. *Telaio di dimensioni contenute, tale da essere inserito in qualsiasi struttura e capace di pilotare cinescopi da 14" a 26" 90° o 110° normali o ad alto fuoco.*

Con queste caratteristiche siamo convinti di fornire con il monitor MTC 900 HRS, nelle sue versioni, un prodotto in grado di soddisfare tutte le esigenze nel settore Video a colori.

F

L'expérience acquise par la Société HANTAREX dans le secteur des moniteurs a permis la réalisation du nouveau MTC HRS qui marque une étape futuriste dans l'ajournement technologique constant poursuivi par la Société.

La sigle HRS abréviation de High Reliability Series, qualifie et garantit l'appareillage comme «série de haute fiabilité» obtenue moyennant un HRS PLANT, c'est à dire un plan de programmation et production de type professionnel particulièrement étudié pour garantir la fiabilité maxima du produit et par conséquent sa longue durée.

Les points essentiels qui ont permis d'atteindre ce haut niveau de qualification sont:

1. *Projet électronique et mécanique particulièrement suivi en ce qui concerne la fiabilité et l'élimination de tous les contacts entre les fiches moyennant l'emploi de deux seuls modules horizontaux.*
2. *Sélection soignée des composants moyennant l'acceptation de ceux-ci suivant de très sévères contrôles de qualité (AQL).*
3. *Emploi dans le secteur VIDEO d'un intégré à large bande construit tout exprès pour la Société HANTAREX qui garantit une reproduction optimale des caractères alfa-numériques.*
4. *Circuit de focalisation obtenu avec un BLEEDER, c'est-à-dire grâce à une résistance qui dérive la tension de feu directement de la ventouse EAT. Grâce à ce circuit, les dommages causés par les décharges du cinescope sont pratiquement réduits à néant à l'arrivée au moniteur et aux appareillages qui lui sont reliés.*
5. *Circuit de protection contre l'émission de rayons X à normes internationales.*
6. *Châssis de dimensions réduites prévu pour être inséré dans n'importe quelle structure et capable de guider des cinescopes de 14 à 26", 90° ou 110° normaux ou à haut feu.*

Avec ces caractéristiques propres au moniteur MTC 900 HRS, nous sommes convaincus de fournir un produit capable de satisfaire toutes les exigences dans le secteur VIDEO A COULEURS.

D

Die von der Firma HANTAREX gesammelte Erfahrung auf dem Monitoregebiet hat die Entwicklung des neuen Monitors MTC 900 HRS ermöglicht, der eine weitere Etappe bei der ständigen technologischen Weiterentwicklung seitens der Firma bei der Herstellung ihrer Produkte darstellt.

Die Kurzbezeichnung HRS — für High — Reability — Series, gewährleistet die hohe Zuverlässigkeit des Gerätes, das durch einen HRS-Plant, d.h. einen fachgerechten Entwicklungs- und Fertigungsplan erzielt wurde, der speziell zur höchsten Zuverlässigkeit des Produkts und daher seinen Lebensdauer entwickelt wurde.

Die Hauptmerkmale, die zur Erreichung dieses Qualitätsniveaus beigetragen haben, sind:

1. Sehr sorgfältige Mechanik- und Elektronikplanung hinsichtlich der Zuverlässigkeit und Aufhebung aller Kontakte zwischen den Karten durch die Verwendung von nur zwei Horizontalbausteinen.
2. Sorgfältige Auswahl der Bausteine durch Abnahme der selben nach strengen Qualitätsprüfungen.
3. Verwendung im Bildschirmteil einer breitbandigen integrierten Schaltung, speziell für die Firma HANTAREX hergestellt, die eine optimale Wiedergabe der alphanumerischen Zeichen gewährleistet.
4. Focusschaltung aus einem BLEEDER, d.h. durch einen Widerstand, der die Focusspannung direkt aus der Saugtasche EAT ableitet. Diese Schaltung verringert drastisch die am Monitor und an den mit ihm verbundenen Geräten entstandenen Schäden, und zwar durch Entladungen der Bildröhre.
5. Die Schutzschaltung gegen X-Strahlungen nach internationalen Normen.
6. Platzsparender Rahmen, der zu jedem Aufbau passt und Bildröhren von 14" bis 26", 90° bzw. 110° normal bzw. mit Hochfocuss steuern kann.

Mit diesen Eigenschaften sind wir überzeugt, mit dem Monitor MTC 900 HRS ein Produkt anbieten zu können, das allen Forderungen auf dem Farbbildschirmgebiet Rechnung trägt.

E

La experiencia adquirida por la sociedad HANTAREX en el campo de los monitores ha permitido la realización del nuevo MTC-900 HRS, que señala un última etapa en el constante avance tecnológico perseguido por la Sociedad en la realización de sus productos.

La sigla HRS abreviación de High-Reability-Series, califica y garantiza el aparato como «serie de alta fiabilidad» obtenida mediante un HRS-PLANT, es decir un plano de proyecto y producción de tipo profesional, particularmente estudiado para garantizar la máxima fiabilidad del producto, y por lo tanto su larga duración.

Los puntos esenciales que han permitido el alcance de este nivel de calidad son:

1. El proyecto electrónico y mecánico particularmente cuidados en el campo de la fiabilidad y eliminación de todos los contactos entre circuitos impresos, mediante el uso de sólo dos módulos horizontales.
2. Selección cuidada de los componentes por medio de aceptación de los mismos según severos controles de calidad (AQL).
3. El uso en la sección video de un integrado a banda larga, expresamente construido para la sociedad HANTAREX, que garantiza una óptima reproducción de los caracteres alfa-numéricos.
4. Circuito de focalización extraído con un BLEEDER, es decir mediante una resistencia que deriva a tensión de foco directamente de la ventosa de EAT. Este circuito reduce drásticamente los daños derivados al monitor y a los aparatos a él conectados, de las descargas del tubo.
5. Circuito de protección contra la emisión de rayos X a normas internacionales.
6. Platina y chasis de dimensiones reducidas, de forma que pueden ser introducidos en cualquier estructura y capaz de utilizar tubos desde 14" a 26", 90° ó 110°, normales o de alto foco.

Con estas características estamos convencidos de ofrecer con el Monitor MTC-900 HRS en sus diferentes versiones, un producto capaz de satisfacer todas las exigencias en el sector Video a color.

GR

Ἡ μακροχρόνια πείρα τῆς Ἑταιρείας HANTAREX στὸν τομέα τῶν MONITORS μᾶς παρέχει τὴν δυνατότητα τῆς δημιουργίας τοῦ νέου τύπου MTC 900 HRS πού ἀποτελεῖ ἕνα περαιτέρω τεχνολογικό σταθμόν στὸν τομέα τῶν MONITORS καί ἀξιοποικνεῖ τὴν δυνατότητα τῆς Ἑταιρείας μας στὴν δημιουργία νέων προηγμένης τεχνολογίας προϊόντων.

Ἡ ἔνδειξις H.R.S. (HIGH-REALBILITY-SERIES) ἀποτελεῖ ἐγγύησιν παραγωγῆς προϊόντων ἐξαιρετικῆς ποιότητος πού παράγονται σὲ «σειρά ὑψηλῆς πιστότητος». Τοῦτο ἐπιτυγχάνεται μὲ τὴν ἐφαρμογὴν ἐνός HRS-PLANT, δηλαδὴ μὲ τρόπο σχεδιασμοῦ καί παραγωγῆς προϊόντων ἐπαγγελματικοῦ τύπου, εἰδικά μελετημένων διὰ νὰ παρέχουν ἐγγύησιν ὑψηλότερης ποιότητος καί μεγαλύτερης χρονικῆς διάρκειας.

Οἱ βασικοὶ λόγοι πού μᾶς ἔδωσαν τὴν δυνατότητα νὰ ἐπιτύχουμε αὐτό τό ψηλὸ ποιοτικό ἐπίπεδο, εἶναι!

1. Ὁ εἰδικὰ διὰ τὴν ὑψηλὴ ποιότητα ἠλεκτρονικός καί μηχανικός σχεδιασμός ὡς καί ὁ ἀποκλεισμός ὄλων τῶν ἐπαφῶν τῶν πλακεττῶν μὲ τὴν χρησιμοποίηση δύο μόνων ὀριζοντίων τυπωμένων κυκλωμάτων.
2. Ἡ κατόπιν αὐστηρῶν ἐλέγχων ἐπιλογή τῶν ὑλικῶν (ARL).
3. Ἡ χρησιμοποίησις στοῦ τμήματος VIDEO ἐνός ὀλοκληρωμένου κυκλώματος, εὐρείας μᾶντας, εἰδικῶς κατασκευασμένου γιὰ τὴν Ἑταιρείαν HANTAREX, πού ἐγγυᾶται ἐξαιρετικὴ ἀναπαραγωγὴ ἀριθμημένων χαρακτήρων.
4. Τό κύκλωμα ἐστίασεως πού προέρχεται ἀπὸ ἕνα BLEEDER, δηλαδὴ διὰ μέσου μιᾶς ἀντιστάσεως, πού ἀποκλείει τὴν τάσι τοῦ φωτός κατ'εὐθείαν ἀπὸ τὴν βεντούζα EAT. Αὐτό τό κύκλωμα ἐλαττῶνει δραστικά τίς βλάβες, πού μπορεῖ νὰ προκύψουν στοῦ MONITOR καί τὰ συνδεδεμένα μὲ αὐτό ὄργανα, ἀπὸ τίς ἐκκενώσεις τῶν καθοδικῶν λυχνιῶν.
5. Τό κύκλωμα προστασίας ἀπὸ τὴν ἐκπομπὴ ἀκτίνων X σύμφωνα μὲ τοὺς διεθνῆς κανονισμούς.
6. Τό πλαίσιο περιορισμένων διαστάσεων κατασκευασμένο εἰδικὰ γιὰ νὰ μποροῦν νὰ χρησιμοποιηθοῦν ὀθόνες ἀπο 14" μέχρι 26" 90° ἢ 120° κανονικῆς ἢ μὲ ὑψηλὴ ἐστίαση.

Μὲ αὐτὰ τὰ χαρακτηριστικὰ εἶμαστε πεπεισμένοι ὅτι προσφέροντας τό MONITOR MTC 900 HRS μὲ ὄλες τίς παραλλαγές του, προσφέρομεν ἕνα προϊόν πού εἶναι σὲ θέση νὰ ἱκανοποιήσει ὄλες τίς ἀπαιτήσεις στὸν τομέα τῶν VIDEO COLORS.

CODING

MFD BY HANTAREX s.p.a. 		
ITALY FLORENCE VIA FABRONI 36R		
Mod		Product No.
Chassis No.		Serial No.
Date		By order of
V	A	W

WARNING	
The picture tube in this receiver employs integral implosion protection. Replace only with a tube of the same type for continued safety.	
Serial No.	Product No.

Mod. : MTC 900
 Serial n° : chassis serial number
 Date : Month and year of production
 Product n° : alphanumeric code which marks the type of chassis
 Chassis n° : Code of crt utilized
 By order of : Order reference
 V : Power transformer secondary voltage
 A : Current
 W : Power

Mod. : MTC 900
 Serial n° : Numero di serie del telaio
 Date : Mese e anno di produzione
 Product n° : Codice che contraddistingue i vari tipi di telai
 Chassis n° : Codice del cinescopio utilizzato
 By order of : Codice relativo all'ordinazione
 V : Tensione alternata di alimentazione del monitor
 A : Corrente assorbita dal monitor
 W : Potenza consumata dal monitor
 Serial n° : Codice del cinescopio utilizzato
 Product n° : Codice che contraddistingue il telaio utilizzato.

ATTENTION

- Attention : The chassis and the heat sinkers are not connected to the gnd. For voltage measurements connect your probe - gnd to the acquadag socket's gnd of the CRT.
- Y Rays : Frame has been planned for the minimum X rays emission (issue) therefore, it is absolutely necessary not to modify the high tension board.
- High voltage : The monitor contains high voltage sources capable of producing lethal quantities of energy. Therefore, for obvious safety reasons, adopt the precautions prescribed for work on high voltage equipment.
- Cathode ray tube : The cathode ray tube is a high-vacuum component and, because of its surface area, it is subject to high pressure. Obvious precautions must therefore be taken to avoid knocking or scratching the tube since this could lead to its implosion, with resultant danger to the user and/or the associated circuits. Personnel engaged in installation should therefore wear safety glasses and protective clothing against bombardment by splinters.
Do not handle the tube by the neck.
- Shock : In order to prevent risks of fire and electric shock do not expose the monitor to rain or moisture.

- Attenzione : Il telaio ed i dissipatori di questo monitor non sono collegati a massa. Quindi per la misura delle tensioni connettere il terminale del negativo dello strumento di misura alla massa del circuito stampato dello zoccolo del cinescopio.
- Raggi X : Il telaio è stato progettato per la minima emissione di raggi X, per questo è indispensabile non attuare alcuna modifica al circuito di alta tensione.
- Alta Tensione : Il monitor contiene sorgenti di alta tensione capaci di erogare quantità di energia LETALE. Quindi per evitare danni agli operatori utilizzare le precauzioni previste in caso di interventi su apparecchiature ad alta tensione.
- Tubo a raggi catodici : Il tubo a raggi catodici è un elemento ad alto vuoto e la sua superficie è sottoposta quindi a forti pressioni. Di conseguenza si debbono prendere precauzioni per non urtare o graffiare il tubo poiché ciò potrebbe portare all'implosione dello stesso con conseguente pericolo per l'utilizzatore. Quindi il personale addetto all'installazione, deve usare occhiali ed indumenti protettivi contro il bombardamento da schegge.
- Shock : Per prevenire la possibilità di scariche elettriche non esporre il monitor a pioggia od umidità.

e' un prodotto: **High Reliability Series**

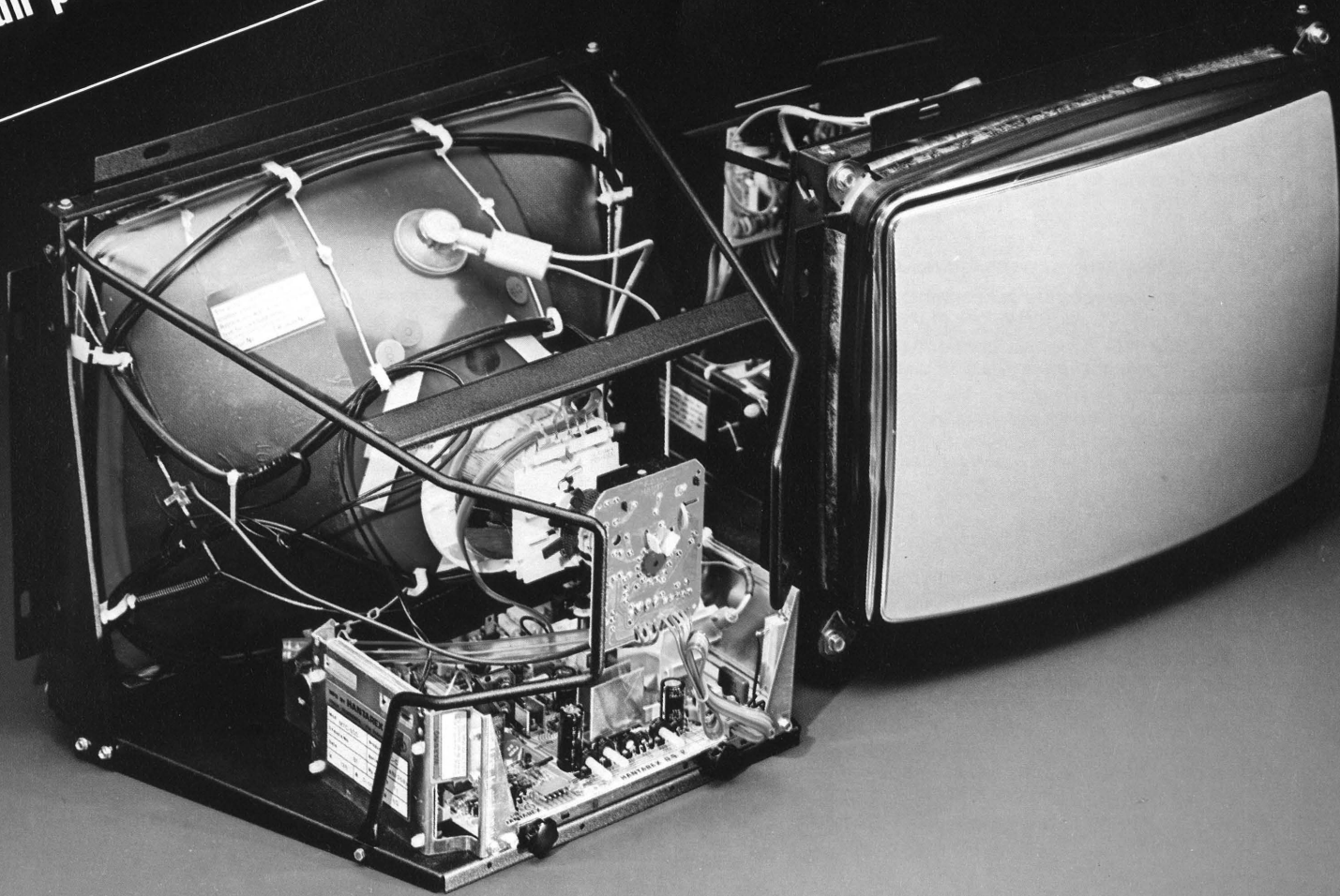

mod. 20"

MTC 900 colour monitor

5

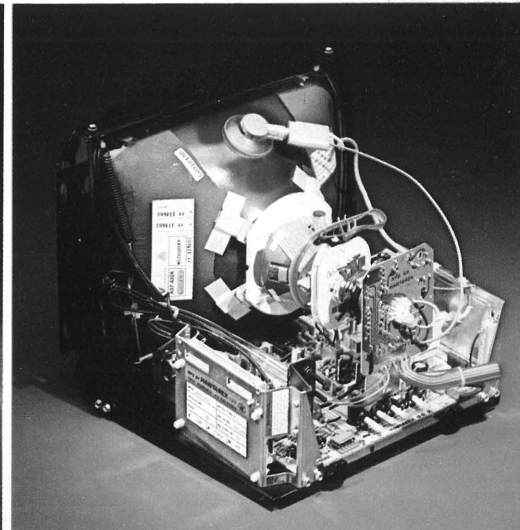
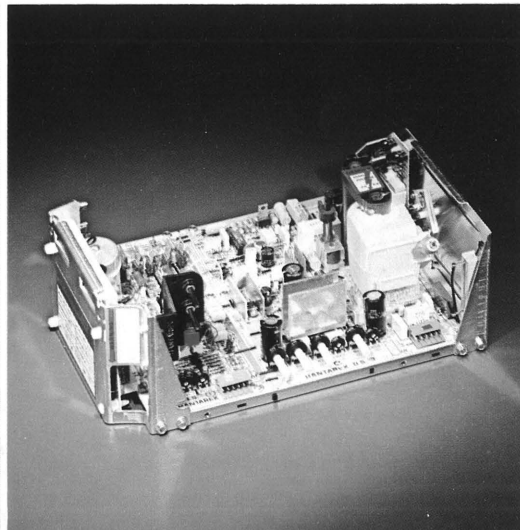
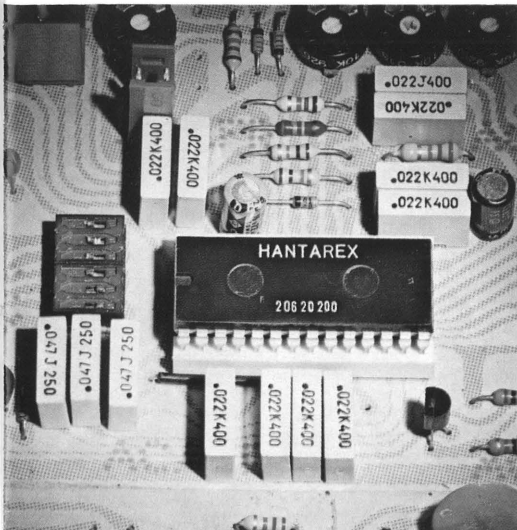

WARNING

GB

1. **SWITCHING-ON** - Warning! - the monitor must be connected via an isolating transformer! providing a nominal output voltage of 125V.ac.
2. **X-RAYS** - the chassis is designed for minimum X-ray emission, and a suitable safety circuit ensures that the value of 0.5 mR/h is never exceeded, even in the event of faults. It is therefore essential not to modify the e.h.t., circuit in any way.
3. **HIGH VOLTAGE** - The monitor contains high voltage sources capable of producing lethal quantities of energy. Therefore, for obvious safety reasons, adopt the precautions prescribed for work on high voltage equipment.
4. **CATHODE - RAY TUBE** - The cathode-ray tube is a high-vacuum component and, because of its surface area, it is subject to high pressure. Obvious precautions must therefore be taken, to avoid knocking or scratching the tube since this could lead to its implosion, with resultant danger to the user and/or the associated circuits.
Personnel engaged in installation should therefore wear safety glasses and protective clothing against bombardment by splinters.
Do not handle the tube by the neck.
5. **SHOCK** - In order to prevent risks of fire and electric shock do not expose the monitor to rain or moisture.

I

1. **ACCENSIONE** - *Attenzione il monitor deve essere acceso tramite un trasformatore di isolamento!*
2. *Il telaio è stato progettato per la minima emissione di raggi X, ed un apposito circuito di sicurezza garantisce che anche in caso di guasti non venga mai superato il valore di 0,5 mR/h. È per questo indispensabile non attuare alcuna modifica al circuito di alta tensione.*
3. **ALTA TENSIONE** - *Il monitor contiene sorgenti di alta tensione capaci di erogare quantità di energia LETALE. Per evitare il pericolo di vita utilizzare le precauzioni previste in caso di lavori su apparecchiature ad alta tensione.*
4. **TUBO A RAGGI CATODICI** - *Il tubo a raggi catodici è un elemento ad alto vuoto ed a causa della sua superficie è sottoposto a forti pressioni. Si debbono quindi prendere ovvie precauzioni per non urtare o graffiare il tubo poiché ciò potrebbe portare all'implosione dello stesso con conseguente pericolo per l'utilizzatore e/o i circuiti annessi. Quindi il personale addetto all'installazione, deve usare occhiali e indumenti protettivi contro il bombardamento da schegge. Non maneggiare il tubo per il collo.*
5. **SHOCK** - *Per prevenire il fuoco o la possibilità di SHOCK elettrici non esporre il monitor a pioggia o umidità.*

F

1. **BRANCHEMENT**: Attention! Le moniteur doit être branché au moyen d'un transformateur d'isolement.
2. **RAYONS X**: le châssis a été prévu pour une émission minima de rayons X et un circuit de sécurité garantit que même en cas de panne, la valeur de 0,5 mR/h n'est jamais dépassée. Pour cette raison il ne faut faire aucune modification au circuit de haute tension.
3. **HAUTE TENSION**: le moniteur contient des sources de haute tension capables de fournir une quantité d'énergie MORTELLE. Pour éviter tout danger, appliquer les précautions d'usage pour les travaux sur appareillages de haute tension.
4. **TUBE A RAYONS CATHODIQUES**: le tube à rayons cathodiques est un élément de haut vide et en raison de sa superficie il est soumis à de fortes pressions. On doit donc prendre de grandes précautions pour ne pas le heurter ou le rayer, ce qui pourrait entraîner une implosion avec graves conséquences pour l'utilisateur et des dommages aux circuits annexes.
Le personnel chargé de l'installation doit mettre des lunettes et des vêtements protecteurs contre les éventuels éclatements de verre.
Ne pas manipuler le tube par le culot.
5. **SHOCK**: pour éviter le feu ou la possibilité de décharges électriques ne pas exposer le moniteur à la pluie ou à l'humidité.

D

1. **EINSCHALTUNG** - *Achtung: Der Monitor muß über einen Isolationstrafo eingeschaltet werden!*
2. **X-STRAHLEN** - *Der Rahmen ist für die minimale X-Strahlung entwickelt und eine geeignete Sicherheitsschaltung gewährleistet, daß auch bei Störungen nie der Wert von 0,5 mR/h überschritten wird. Es ist daher unentbehrlich, keine Änderung an der Hochspannungsschaltung vorzunehmen.*
3. **HOCHSPANNUNG** - *Der Monitor enthält Hochspannungsquellen, die lebensgefährliche Energie erzeugen können. Um die Lebensgefahr zu vermeiden, alle vorgesehenen Maßnahmen für Arbeiten an Hochspannungsgeräten anwenden.*
4. **KATHODENSTRAHLRÖHRE** - *Die Kathodenstrahlröhre ist eine Hochvakuumröhre und aufgrund ihrer Oberfläche steht sie unter starkem Druck. Es sind daher alle Vorkehrungen zu treffen, um gegen sie nicht zu stoßen bzw. nicht zu kratzen, da dieses zur Implosion der selben mit darauffolgender Gefahr für den Verbraucher und/oder die angeschlossenen Schaltungen führen könnte. Das zuständige Aufstellungspersonal muß daher Schutzbrille und Schutzkleidung gegen Splitterungen tragen. Die Röhre nicht am Hals fassen.*
5. **SCHLAG** - *Um Feuer bzw. elektrische Schläge vorzubeugen, Monitor weder dem Regen noch der Feuchtigkeit aussetzen.*

E

1. **ENCENDIDO** - Atención el monitor debe ser encendido mediante un transformador de aislamiento!
2. **RAYOS X** - La platina ha sido proyectada para la mínima emisión de rayos X, y un específico circuito de seguridad garantiza que también en caso de fallo nunca se supere el valor de 0,5 mR/h. Es por esto indispensable no ejercer ninguna modificación al circuito de alta tensión.
3. **ALTA TENSION** - *El monitor tiene fuentes de alta tensión capaces de producir una gran cantidad de energía letal. para evitar peligro de muerte, utilizar las precauciones previstas en los casos de trabajo sobre aparatos de alta tensión.*
4. **TUBO DE RAYOS CATODICOS** - El tubo de rayos catódicos es un elemento de alto vacío y debido a su superficie está sometido a fuertes presiones. Se debe, por lo tanto, tomar obvias precauciones para no golpear o rayar el tubo ya que esto podría llevar a la implosión del mismo, con el consiguiente peligro para el usuario y/o los circuitos anexos.
Por lo tanto el personal encargado de la instalación debe usar gafas e indumentaria protectora contra el bombardeo de fragmentos. No manejar el tubo por el cuello.
5. **SHOCK** - Para prevenir el fuego o la posibilidad de SHOCK eléctrico no exponer el monitor a lluvia o humedad.

GR

1. ΘΕΣΙΣ ΣΕ ΛΕΙΤΟΥΡΓΙΑ - Προσοχή, τό MONITOR πρέπει νά τεθή σέ λειτουργία διά μέσου ενός μετασχηματισμού απομονώσεως.
2. ΑΚΤΙΝΕΣ X - Τό σασσί είναι σχεδιασμένο γιά τήν ελάχιστη έκπομπή ακτίνων X καί ένα ειδικό κύκλωμα ασφαλείας, έγγυάται σέ περίπτωση βλάβης νά μήν υπερβή τό 0,5 MR/H καί γι 'αυτό συνιστάται νά μή γίνη καμία αλλαγή στό κύκλωμα τής υπερυψηλής τάσεως.
3. ΥΠΕΡΥΨΗΛΗ ΤΑΣΙΣ - Τό MONITOR περιέχει πηγές υψηλής τάσεως, δυνάμενες νά παράγουν ενέργεια LETALE. Διά νά αποφευχθή κίνδυνος ζωής, πρέπει νά λαμβάνονται τά ένδεικνυόμενα μέτρα, πού λαμβάνονται σέ περίπτωση χρησιμοποίησεως συσκευών υψηλής τάσεως.
4. ΛΥΧΝΙΑ ΚΑΘΟΔΙΚΩΝ ΑΚΤΙΝΩΝ - Ή λυχνία καθοδικών ακτίνων έχει απόλυτο κενό άέρος καί σέ περίπτωση κτυπήματος μπορεί νά έκραγῆ. Γι 'αυτό δέν πρέπει νά δέχεται κτυπήματα ἢ γρατζουνίσματα. Τό προσωπικό πού ασχολείται μέ αυτές πρέπει νά φορά προστατευτικά γυαλιά καί κατάλληλα ροθχα. Δέν πρέπει νά σηκώνουμε τήν λυχνία κρατώντας αυτήν από τό λαϊμό.
5. SHOCK - Για τήν άποφυγή κινδύνου φωτιάς ἢ ηλεκτρικού SHOCK, δέν πρέπει νά έκτίθεται τό MONITOR σέ βροχή ἢ υγρασία.

TECHNICAL CHARACTERISTIC

MTC 900 SERIES T_a 25° C

DESCRIPTION		MIN	TYP	MAX	UNITS
Supply					
INPUT ac	monitor input-with insulation transformer	108	128	141	Vac
POWER			85		W
DEGAUSSING	automatic		115		Vac
Interface					
VID. SIGN. INPUT	RGBsignal: positive or negative digital or analog	1	4	10	Vpp
SYNC. INPUT	TTL compatible separate horizontal and vertical or composite				
	(H+V) positive or negative Input	1,5	4	5,5	Vpp
BLANKING	Horizontal retrace/blanking time		11		μS
VIDEO	Frequency response (-3 db)		8		MHz
	Rise time		50		nS
	Over shoot		0,5	3	%
BEAM-LIMITER	Beam current		1		mA
CONTROLS	Brightness and contrast		100		%
Deflection					
GEOMETRY	Horizontal linearity		± 6		%
	Vertical linearity		± 10		%
	Pincushion		± 3		%
	Horizontal scan size		-4 +10		%
	Vertical scan size		± 15		%
Convergence					
	Self converging				
Quality					
	Major			2,5	%
	Minor			6	%
EHT					
EHT	(115Vdc 0beam current)	23	24	25	KV
X-RAY SAFETY	Firing		26,5		KV
X-RAY	Emission			≤0,25	mR/h
CRT					
90° & 110° SERIES	Precision in line 14" 16" 20" 22" 26" normal or high focus				
MANUFACTURES	ITT PHILIPS RCA VIDEOCOLOR TOSHIBA HITACHI				

OPERATING DATA

GB

INSTALLATION - The monitor is provided with inputs as listed below:

1. **POWER SUPPLY** - Connect 128 V a. c. 50/60 Hz via an isolating transformer capable of delivering 0.75A to terminals 1 and 2 with connector CB.
2. **DEGAUSSING CIRCUIT** - Connect the mains (220 V or 110 V a.c.) direct to terminals 3 and 4 of connector CB, the degaussing coils to terminals 1 and 2 of connectors CD, the degaussing pushbutton to terminals 1 and 2 of connector CC. The pushbutton is mounted on a bracket and connected by a flying lead and should be placed in a position which is accessible from the outside.
3. **RGB VIDEO SIGNALS** - Connector CA Terminal 1 blue input; Terminal 2 green input; Terminal 3 red input. For POSITIVE video signals connect CX to position A, for negative video connect CX to position B
4. **SYNCHRONISATION SIGNALS** - Connector CA: Terminal 6 composite (H + V) or vertical sync., Terminal 5 horizontal sync., Terminal 4 ground. For positive sync. switch CY to A, for negative sync. switch CY to B;
5. **CALIBRATION OF VIDEO INPUT LEVELS** - Connect the signals to the RGB inputs and adjust RVI for BLUE, RV2 for GREEN, RV3 for RED until $2V_{pp} \pm 5\%$ is obtained at TP1 - TP2 - TP3 respectively.
6. **BRIGHTNESS AND CONTRAST** - After having correctly connected the power supply and the input signals, briefly press the degaussing button, then adjust the brightness and contrast for a satisfactory picture. These controls which are mounted on a bracket are removable by unscrewing the screws 5 (Fig. X) and may be mounted remote from the chassis. If after this, further adjustment is required, refer to Fig. X for the position of the various controls and to the alignment instructions to obtain correct adjustment. All the input signals must have the characteristics described in Table X.

I

INSTALLAZIONE - Il monitor viene fornito con gli ingressi predisposti nel modo sottoelencato:

1. **ALIMENTAZIONE** - Collegare 128 V CA 50/60 Hz tramite un trasformatore isolatore capace di erogare 500 mA ai terminali 1 e 2 col connettore CB.
2. **CIRCUITO DI SMAGNETIZZAZIONE** - Collegare la rete diretta (220V o 110V CA ai terminali 3 e 4 del connettore CB. le bobine di smagnetizzazione ai terminali 1 e 2 del connettore CD, il pulsante di smagnetizzazione ai terminali 1 e 2 del connettore CC - il pulsante è asportabile e va posto in posizione accessibile dall'esterno.
3. **SEGNALI VIDEO RGB** - Connettore CA; terminale 1 ingresso bleu; Terminale 2 ingresso Verde, Terminale 3 ingresso rosso. Per segnali video POSITIVI porre CX in posizione A, per video negativo CX in B.
4. **SEGNALI DI SINCRONIZZAZIONE** - Connettore CA terminale 6 sinconismo verticale composito (H + V) terminale 5 sincronismo orizzontale. Terminale 5 massa. Per sincronismo positivo, commutare CY in A, per sincronismi negativi CY in B.
5. **TARATURA LIVELLI DI INGRESSO VIDEO** - Collegare i segnali agli ingressi RGB a regolare RV1 per il BLU , RV2 per il VERDE, RV3 per il ROSSO, fino ad ottenere $1V_{pp} \pm 5\%$ sui TP1 -TP2 - TP3 rispettivamente.
6. **LUMINOSITÀ E CONTRASTO** - Dopo avere correttamente collegati l'alimentazione ed i segnali di ingresso, premere il pulsante di smagnetizzazione e regolare quindi la luminosità ed il contrasto in maniera da avere una immagine soddisfacente. Tali comandi sono asportabili mediante l'estrazione delle viti (fig. X) e possono essere portati in posizione accessibile dall'esterno dell'apparecchiatura. Nel caso che dopo queste regolazioni il monitor necessitasse di alcuni ritocchi, riferirsi alla figura X per la posizione dei vari comandi ed alle istruzioni di taratura per un corretto aggiustamento. Tutti i segnali di ingresso debbono avere le caratteristiche descritte in TAB X.

F

INSTALLATION: Le moniteur est fourni avec les entrées prédisposées de la façon suivante:

1. **ALIMENTATION:** relier 128 VCA 50/60 Hz au moyen d'un transformateur isolant capable de fournir 500 mA aux extrémités 1 et 2 avec le connecteur CB.
2. **CIRCUIT DE DEMAGNETISATION:** relier le réseau direct (220 V ou 110 v CA) aux extrémités 3 et 4 du connecteur CB, les bobines de démagnétisation aux extrémités 1 et 2 du connecteur CD, le bouton de démagnétisation aux extrémités 1 et 2 du connecteur CC. Le bouton est amovible et se met en position accessible de l'extérieur.
3. **SIGNAUX VIDEO RGB:** Connettore CA, extrémité 1, entrée bleue, extrémité 2 entrée verte, extrémité 3, entrée rouge. Pour des signaux video POSITIFS mettre C en position A; pour video NEGATIF, CX en B/
4. **SIGNAUX DE SYNCHRONISATION:** connecteur CA extrémité 6 synchronisme vertical composite (H + V) extrémité 5 synchronisme horizontal, extrémité de masse. Pour synchronisme positif, changer CY en A, pour synchronisme négatif CY en B.
5. **REGLAGE NIVEAUX D'ENTREE VIDEO:** relier les signaux aux entrées RGB et régler RV 1 pour le bleu, RV 2 pour le vert, RV 3 pour le rouge jusqu'à l'obtention de $1 V_{pp} \pm 5\%$ sur respectivement TP1, TP2, TP3.
6. **LUMINOSITE ET CONTRASTE:** après avoir correctement relié l'alimentation et les signaux d'entrée, appuyer le bouton de démagnétisation et régler la luminosité et le contraste de façon à obtenir une image satisfaisante. Ces commandes sont amovibles grâce à l'extraction des vis (fig. X) et peuvent être placées en position accessible de l'extérieur de l'appareillage. Si après ces réglages le moniteur nécessite quelques retouches, se reporter à la figure X pour la position des différentes commandes et aux instructions de réglage pour un ajustement correct. Tous les signaux d'entrée doivent avoir les caractéristiques décrites dans TAB X.

D

AUFSTELLUNG - Der Monitor wird mit den Eingängen wie nachstehend angegeben geliefert.

- 1. VERSORGUNG** - 128 V Wechselstrom 50/60 Hz durch einen Isolationstrafo verbinden, der 500 mA für die Terminals 1 und 2 erzeugen kann, mit dem Verbinder CB.
- 2. ENDMAGNETISIERUNGSSCHALTUNG** - Das Direktnetz (220 V bzw. 110 V) Wechselstrom mit den Terminals 3 und 4 des Verbinders CB, die Endmagnetisierungsspulen mit den Terminals 1 und 2 des Verbinders CD, die Endmagnetisierungstaste mit den Terminals 1 und 2 des Verbinders CC verbinden. Die Drucktaste ist abnehmbar und ist an einer zugänglichen Stelle von außen anzubringen.
- 3. RGB - VIDEOSIGNALE** - Verbinder CA; Terminal 1 Blauingang; Terminal 2 Grüneingang; Terminal 3 Roteingang - für Positivvideosignale CX in Stellung A bringen, für Negativvideo CX in Stellung B.
- 4. SYNCHROSIGNALE** - Verbinder CA Terminal 6 Kompoundvertikalsynchro (H + V) Terminal 5 Horizontalsynchro, Terminal 4 Masse - für Positivsynchro CY auf A umschalten, für Negativsynchro CY auf B umschalten.
- 5. EICHUNG VIDEOEINGANGSPEGEL** - RGB-Eingangssignale verbinden und RV1 für BLAU, RV2 für GRÜN, RV3 für ROT einstellen, bis jeweils 1 V pp \pm 5% an den TP1 TP2 TP3 erreicht wird.
- 6. HELLIGKEIT UND KONTRAST** - Nachdem die Versorgung und Eingangssignale richtig verbunden sind, Endmagnetisierungstaste drücken und dann Helligkeit und Kontrast so einstellen, daß ein zufriedenstellendes Bild erreicht wird. Diese Bedienungen sind durch Abnahme der Schrauben (Abb. X) abnehmbar und können in einer zugänglichen Stellung von der Außenseite des Gerätes angebracht werden. Falls nach diesen Einstellungen weitere Verbesserungen am Monitor erforderlich werden, Abb. X für die Lage der Verschiedenen Bedienungen sowie die Eichungshinweise für eine richtige Einstellung zugrunde legen. Alle Eingangssignale müssen die in der Tabelle X aufgeführten Eigenschaften aufweisen.

E

INSTALACION - El monitor viene suministrado con las entradas predispuestas en la forma abajo indicada:

- 1. ALIMENTACION** - Conectar 128V CA 50/60 Hz por medio de un transformador aislante capaz de suministrar 500 mA a los terminales 1 y 2 del conector CB.
- 2. CIRCUITO DESMAGNETIZADOR** - Conectar la red directa 220 V ó 110 V CA a los terminales 3 y 4 del conector CB, Las bobinas desmagnetizadoras a los terminales 1 y 2 del conector CD, el pulsante de desmagnetización a los terminales 1 y 2 del conector CC - El pulsador es móvil y deben ponerse en una posición accesible desde el exterior.
- 3. SENALES VIDEO RGB** - Conector CA; terminal 1 entrada Azul; Terminal 2 entrada Verde; Terminal 3 entrada Roja - Para señales video POSITIVO poner CX en posición A, para video NEGATIVO CX en B.
- 4. SENALES DE SINCRONIZACION** - Conector CA terminal 6 sincronismo vertical compuesto (H + V) terminal 5 sincronismo horizontal, Terminal 4 masa - Para sincronismo positivo, conmutar CY en A, para sincronismo negativo CY en B.
- 5. REGULACION NIVELES DE ENTRADA VIDEO** - Conectar las señales de ingreso RGB y regular RV1 para el AZUL, RV2 para el VERDE, RV3 para el ROJO, hasta obtener 1Vpp \pm 5% sobre TP1 - TP2 - TP3 respectivamente.
- 6. LUMINOSIDAD Y CONTRASTE** - Después de haber conectado correctamente la alimentación y las señales de ingreso, presionar el pulsador desmagnetizador y regular a continuación la luminosidad y el contraste para obtener una imagen satisfactoria. Tales mandos son extraídos mediante tuercas de sujeción y pueden ser transportados a una posición accesible desde el exterior del aparato. En el caso que después de estas regulaciones el monitor necesitara de algunos retoques, referirse a la figura X para la posición de los varios mandos y a las instrucciones de regulación para un correcto ajuste. Todas las señales de ingreso deben tener las características descritas en la TAB X.

GR

ΤΟΠΟΘΕΤΗΣΙΣ ΕΙΣΟΔΩΝ! Στο MONITOR υπάρχουν οί έξι είσοδοι!

- 1. ΤΡΟΦΟΔΟΣΙΑ** - Θέτουμε την τάση 128 VCA 50/60 HZ διά μέσου ενός μετασχηματιστού απομονώσεως 500 MA στά τερματικά 1 και 2 του φίς CB.
- 2. ΚΥΚΛΩΜΑ ΑΠΟΜΑΓΝΗΤΙΣΜΟΥ** - Θέτουμε την τάση δικτύου 220V ή 110VCA° στά τερματικά 3 και 4 του φίς CB, τά πηνία απομαγνητισμού στά τερματικά 1 και 2 του φίς CD, τό μπουτόν του απομαγνητισμού στά τερματικά 1 και 2 του φίς CC. Τό μπουτόν αυτό είναι πάνω στό σασσί αλλά μπορεί και νά τοποθετηθή σέ κάποιο έξωτερικό σημείο.
- 3. ΣΗΜΑ VIDEO RGB** - Φίς CA: Τερματικό 1 είσοδος μπλέ, τερματικό 2 είσοδος πράσινο, τερματικό 3 είσοδος κόκκινο. Για τά ΘΕΤΙΚΑ σηματα VIDEO νά τοποθετηθή τό CX σέ θέση A, για τά ΑΡΝΗΤΙΚΑ σηματα VIDEO τό CX σέ θέση B.
- 4. ΣΗΜΑΤΑ ΣΥΓΧΡΟΝΙΣΜΟΥ** - Φίς CA τερματικό 6 συγχρονισμός κάθετος σύνθετος (H - V) τερματικό 5 συγχρονισμός οριζόντιος τερματικό 4 γείωση. Για συγχρονισμό άρνητικό ό διακόπτης CY νά τεθή στην θέση A, για συγχρονισμό άρνητικό ά διακόπτης CY στην θέση B.
- 5. ΡΥΘΜΙΣΙΣ ΣΤΑΘΜΗΣ ΕΙΣΟΔΟΥ VIDEO** - Τοποθετούνται τά σηματα στάς εισόδους RGB και νά ρυθμισθούν RV1 γιατί μπλέ, RV2 για τό πράσινο, RV3 για τό κόκκινο, μέχρι νά έχουμε IVpp \pm 5% στά TP1 - TP2 - TP3 διαδοχικώς.
- 6. ΦΩΤΕΙΝΟΤΗΣ ΚΑΙ ΚΟΝΤΡΑΣΤ** - Μετά άπό την σωστή τοποθέτηση της τροφοδοσίας και των σωμάτων εισόδου, πιέζουμε τό κομβίον του απομαγνητισμού και ρυθμίζουμε την φωτεινότητα και τό κοντράστ για νά έχουν μία σωστή εικόνα. Τά κομβία αυτά μπορούμε νά τά αφαιρέσουμε, άφου βγάλουμε τίς βίδες (είκόνα X) και μπορούν νά τοποθετηθούν στό έξωτερικό μέρος της συσκευής. Σέ περίπτωση που τό MONITOR μετά άπ'αυτές τίς ρυθμίσεις χρειάζεται μερικές μικρορυθμίσεις, μπορούμε νά δοϋμε την εικόνα X για την σωστή θέση των πλήκτρων και τίς οδηγίες για μία σωστή ρύθμιση. Όλα τά σώματα εισόδων πρέπει νά έχουν τά χαρακτηριστικά TAB X.

INPUT WAVEFORMS

VIDEO SIGNAL-JCA PIN 1-2-3

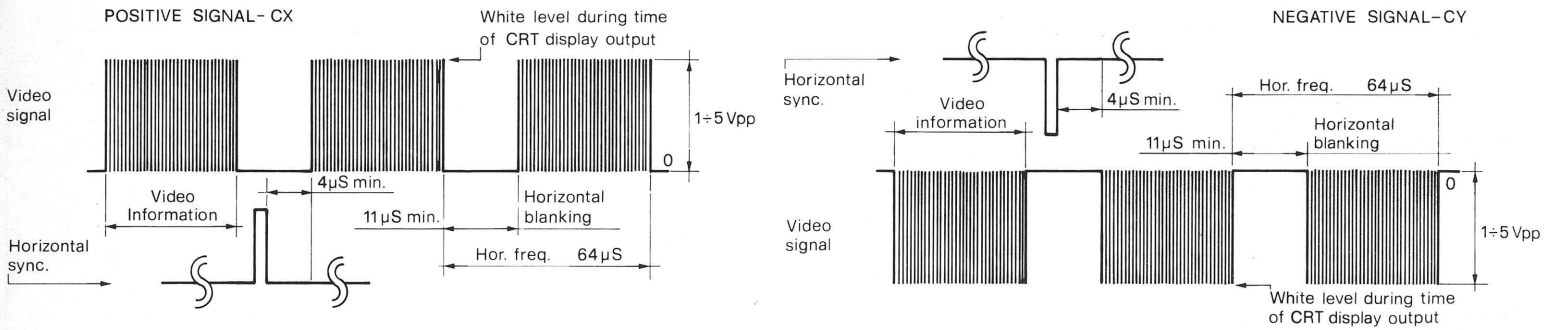

HORIZONTAL SYNC. SIGNAL-JCA PIN 5



VERTICAL SYNC. SIGNAL-JCA PIN 6

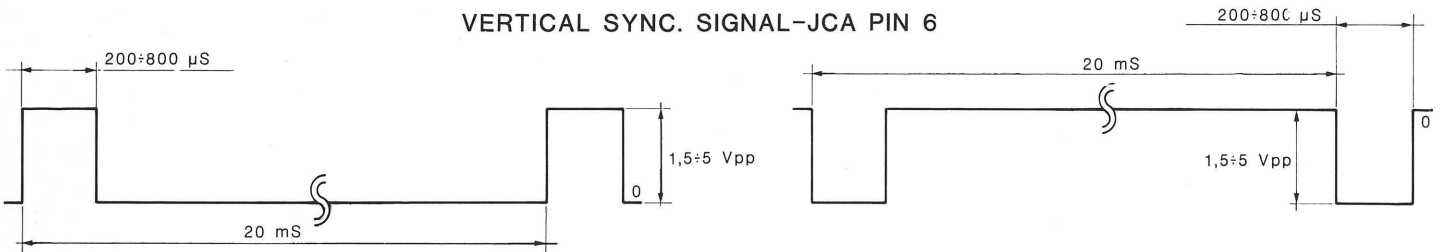

H+V POSITIVE OR NEGATIVE SYNC.(only positive drawn)

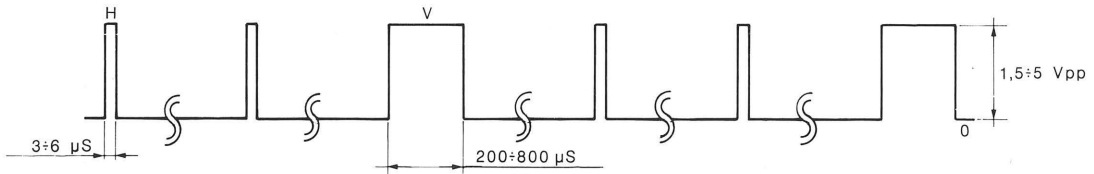

VIDEO SIGNAL RGB AT TP12-TP13-TP14

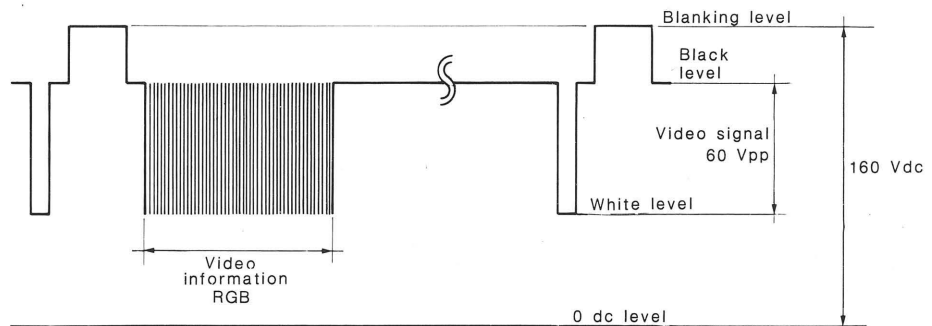

ADJUSTING TRIMMERS

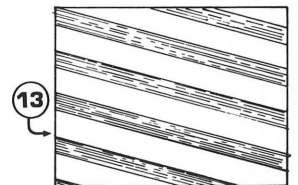
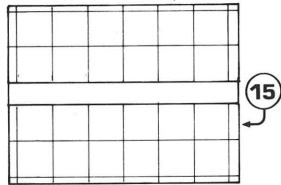
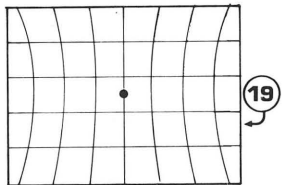
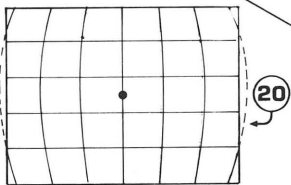
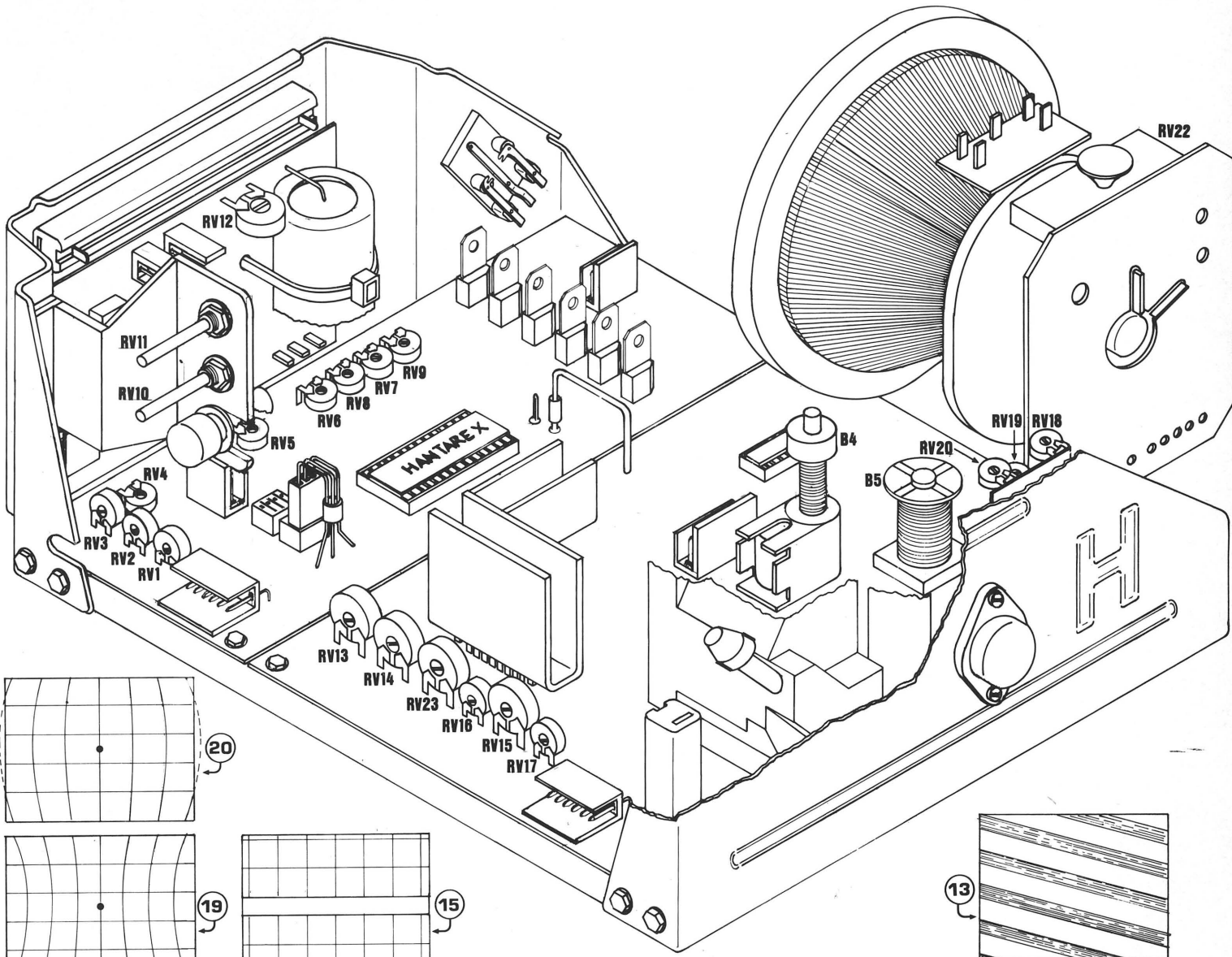

- | | | | |
|---|--|---|--|
| 1 LIVELLO DI INGRESSO BLU
<i>blue input level</i> | 2 LIVELLO DI INGRESSO VERDE
<i>green input level</i> | 3 LIVELLO DI INGRESSO ROSSO
<i>red input level</i> | 4 LIMITAZIONE CORRENTE DI FASCIO
<i>beam current control</i> |
| 5 GUADAGNO DEL VERDE
<i>green gain</i> | 6 GUADAGNO DEL BLU
<i>blue gain</i> | 7 LIVELLO IN D.C. DEL BLU
<i>blue dc level</i> | 8 LIVELLO IN D.C. DEL VERDE
<i>green dc level</i> |
| 9 LIVELLO IN D.C. DEL ROSSO
<i>red dc level</i> | 10 CONTRASTO
<i>contrast</i> | 11 LUMINOSITA'
<i>brightness</i> | 12 REGOLAZIONE ALIMENTAZIONE
<i>power supply</i> |
| 13 FREQUENZA ORIZZONTALE
<i>horizontal hold</i> | 14 FASE ORIZZONTALE
<i>horizontal shift</i> | 15 FREQUENZA VERTICALE
<i>vertical hold</i> | 16 LINEARITA' VERTICALE
<i>vertical linearity</i> |
| 17 AMPIEZZA VERTICALE
<i>height</i> | 18 AMPIEZZA ORIZZONTALE
<i>width</i> | 19 EFFETTO CUSCINO ESTERNO
<i>peripheral pincushion</i> | 20 EFFETTO CUSCINO INTERNO
<i>central pincushion</i> |
| 21 REGOLAZIONE G2
<i>cutoff G2 (pre-set brightness)</i> | 22 REGOLAZIONE FUOCO
<i>focus</i> | 23 SPOSTAMENTO VERTICALE
<i>vertical shift</i> | 24 BOBINA DI LINEARITA'
<i>linearity coil</i> |

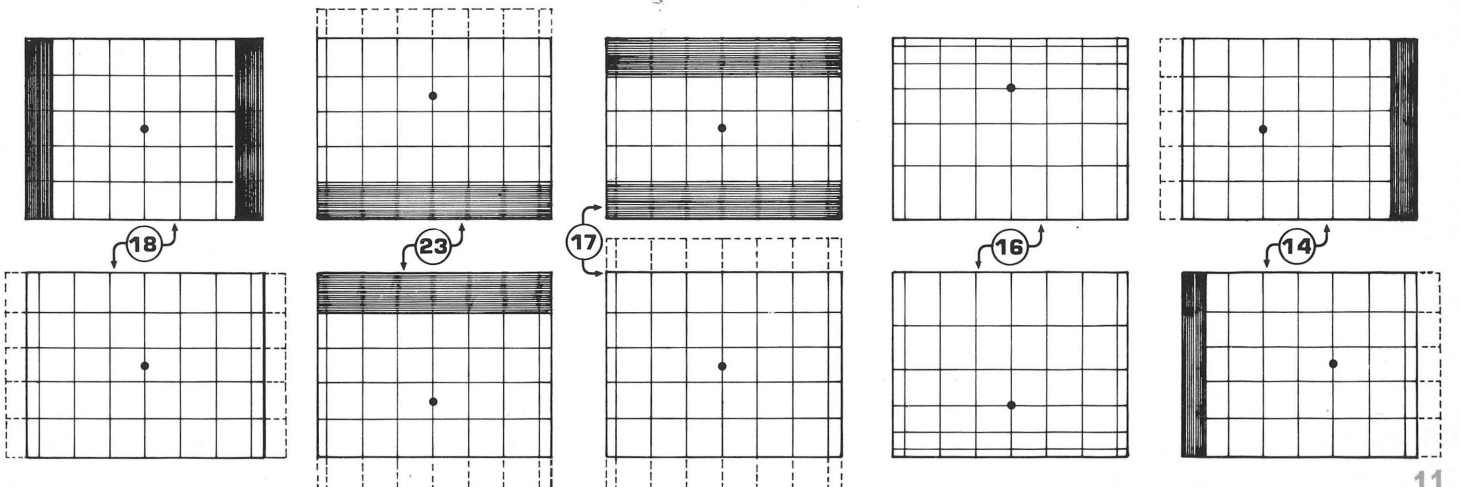

PROTECTION AGAINST X-RAY RADIATION

patent N° 91830158.4

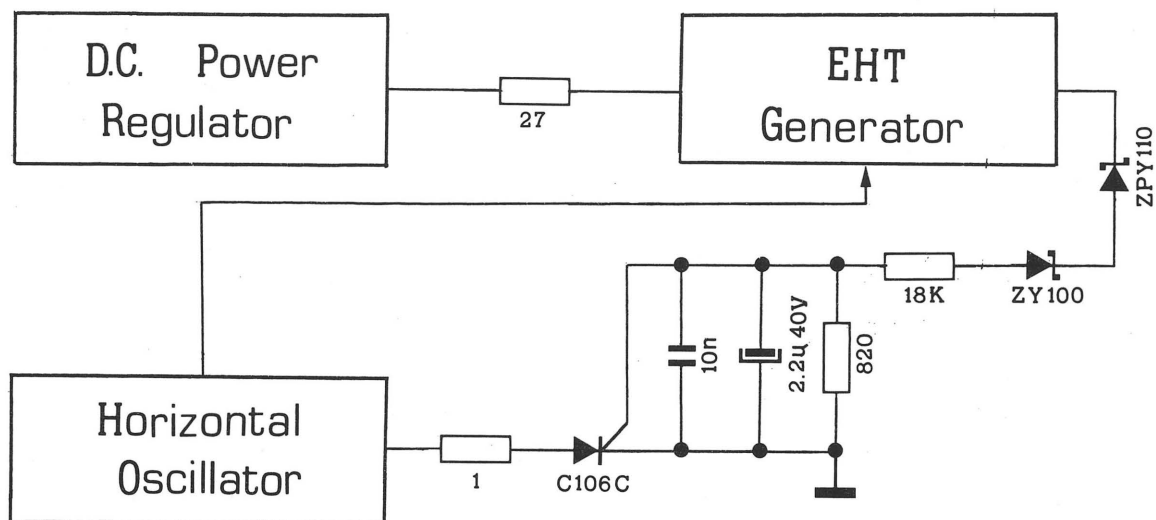

DESCRIPTION OF THE PROTECTION CURRENT AGAINST X-RAY.

In the chassis MTC 900 - a special protection circuit has been introduced to avoid cinescope radiation which can surpass or be at the high limit established by law which is 0,5 mr/h in case of failure on critical components. The protection circuit has, a reference, a tension of 200V taken by the secondary of the transformer EHT and sending it, by way of a resistive divider, to the gate of a SCR.

In case of failure the nominal EHT tension of 25, 5 KV will increase until firing of SCR. Upon firing the SCR by-passes the alimentation to the integrated horizontal oscillator circuit. Thereby stopping the oscillation and, at the same time, the EHT generation. In order to re-establish its function it is enough to trouble shoot and to switch on the set again. The circuit is calculated in a way as to function at a nominal EHT of 27 KV.

In these conditions with the regulation of the chassis in the worst radiation condition and within the presence of any critical component failure it will not surpass the value of 0,15 mR.

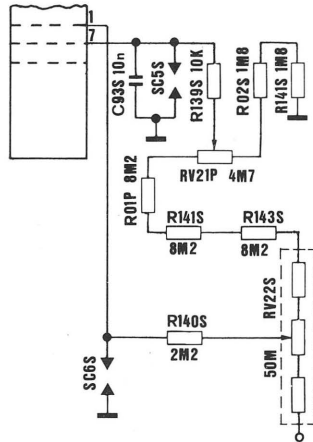
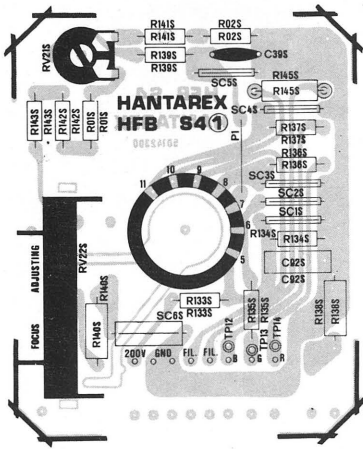

VIDEOCOLOR PICTURE TUBE

- 14" 90° HIGH FOCUS A37-420X
CODE No. 02190060
- 16" 90° HIGH FOCUS A42-420X
CODE No. 02190050
- 20" 90° HIGH FOCUS A51-421X
CODE No. 02190080

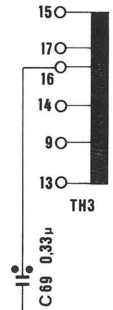

PIN 6 CONNECTOR CL
HORIZONTAL YOKE

DS 62000580

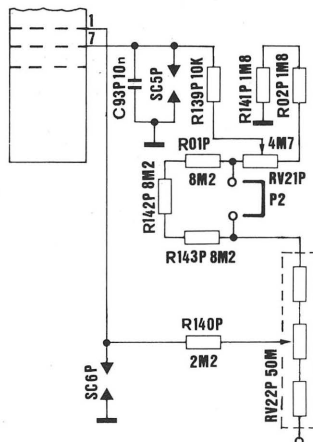
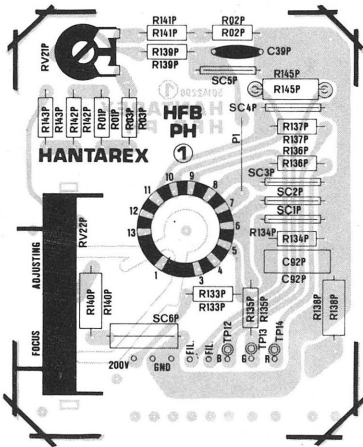

ITT PICTURE TUBE

- 20" 90° HIGH FOCUS A51-230X
CODE No. 02190100

PHILIPS PICTURE TUBE

- 20" 90° HIGH FOCUS A51-580X
CODE No. 02111000
(RV22P : 83M ; SHUNT P2)

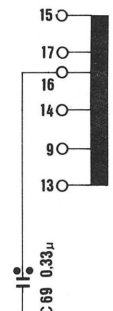

PIN 6 CONNECTOR CL
HORIZONTAL YOKE

DS 62000580

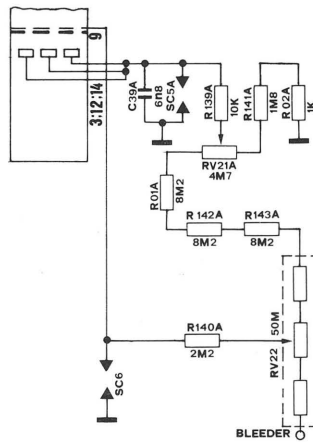
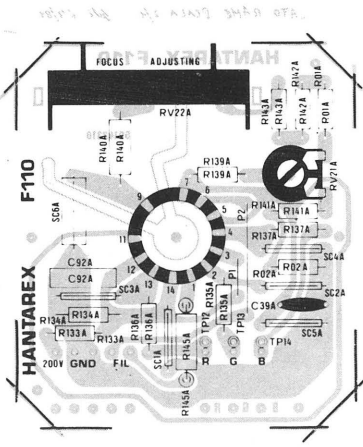

30AX PHILIPS PICTURE TUBE

- 20" 110° HIGH FOCUS A51-540X
CODE No. 02111020
- 22" 110° HIGH FOCUS A56-540X
CODE No. 02111022
- 26" 110° HIGH FOCUS A66-540X
CODE No. 02111026

DRIVER 200v PIN 5 EAST-WEST

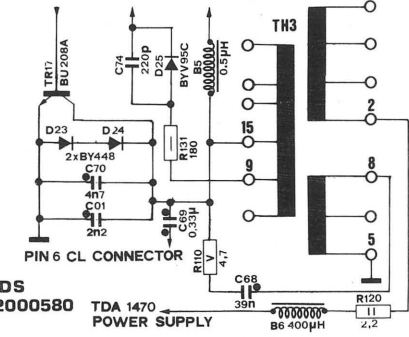

DS 62000580

TDA 1470
POWER SUPPLY

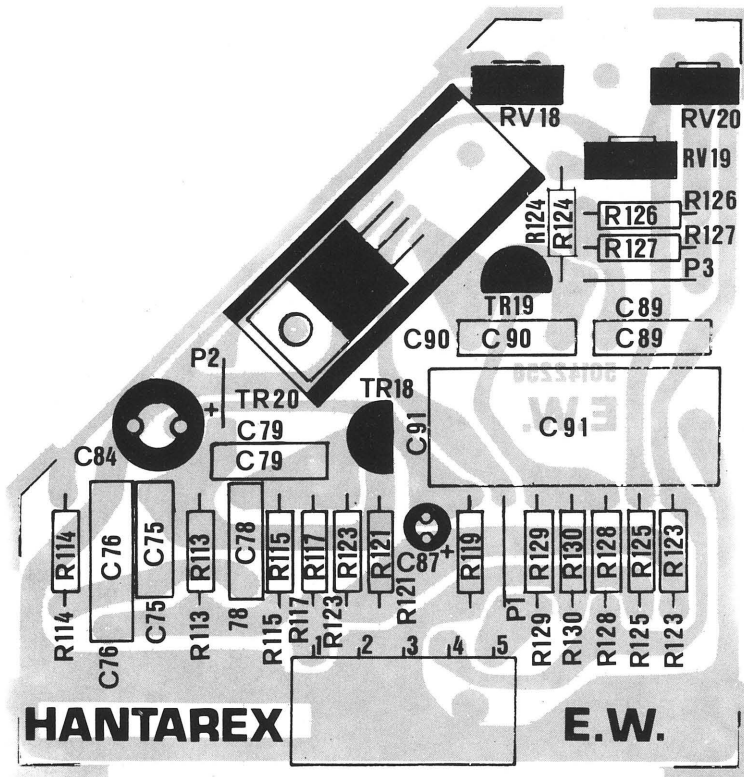

EAST-WEST E.W.

POWER SUPPLY BOARD U.S.

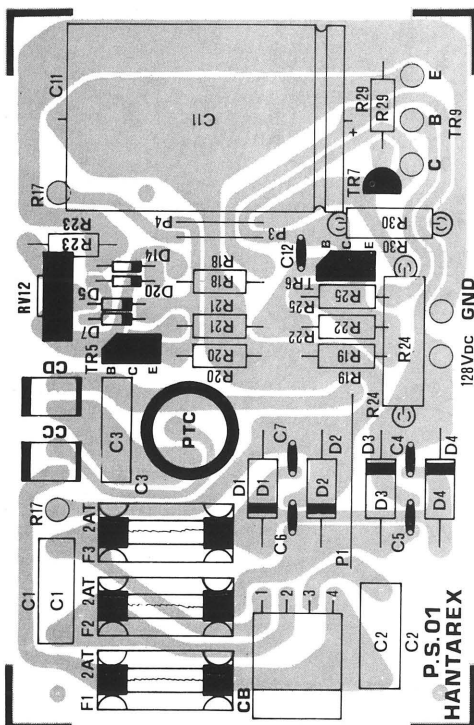

NECK BOARD F.B.

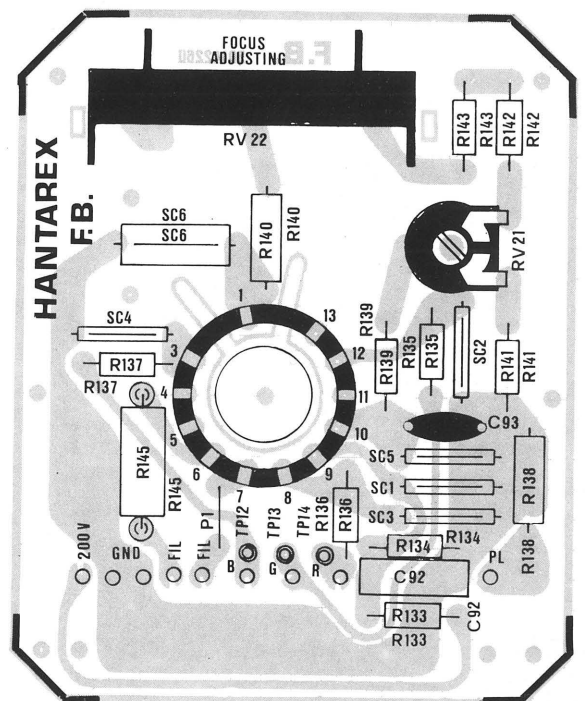

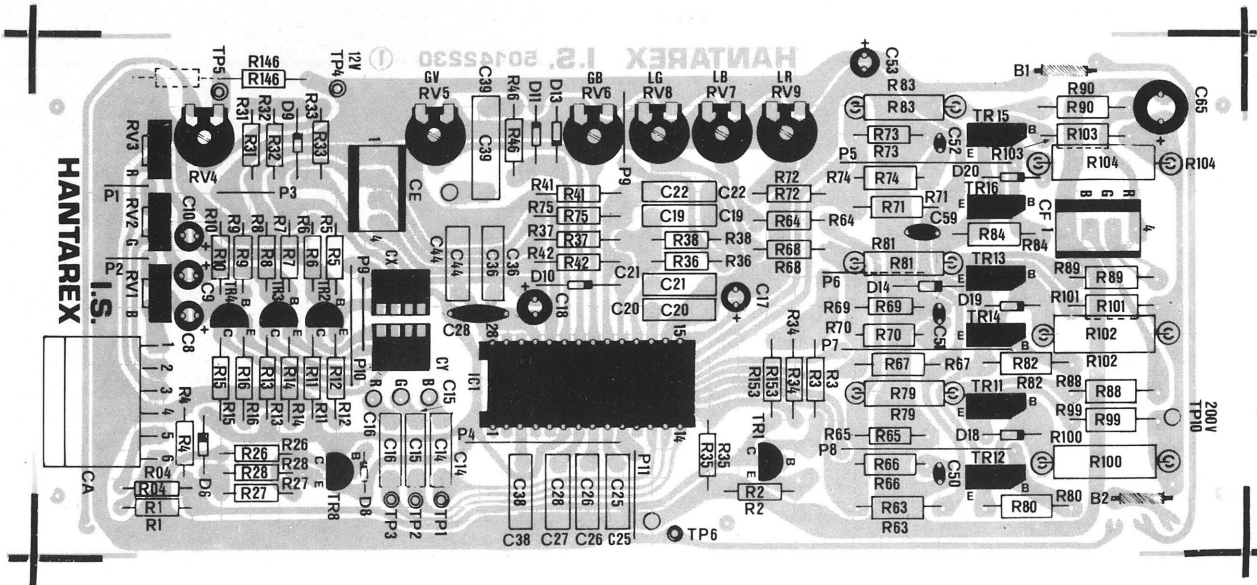

INTERFACE BOARD I.S.

DEFLEXION BOARD D.B.

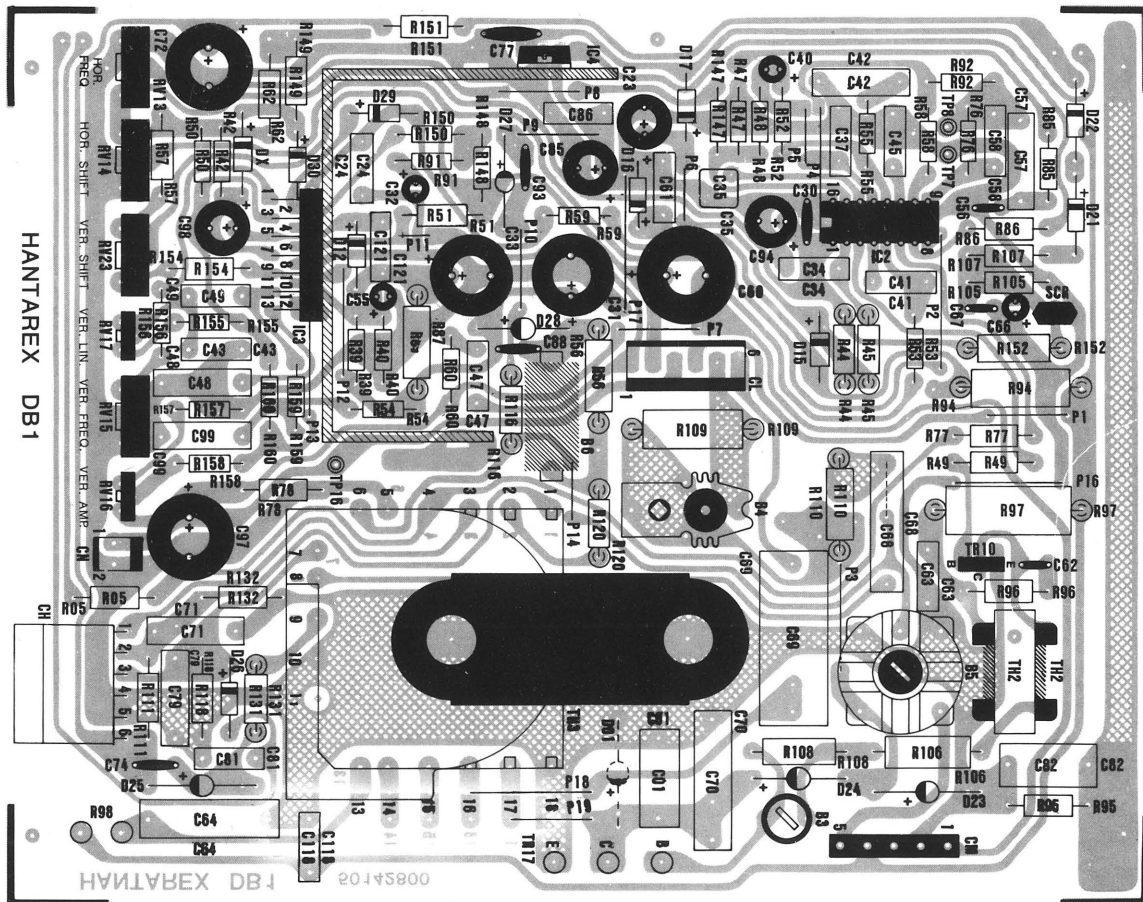

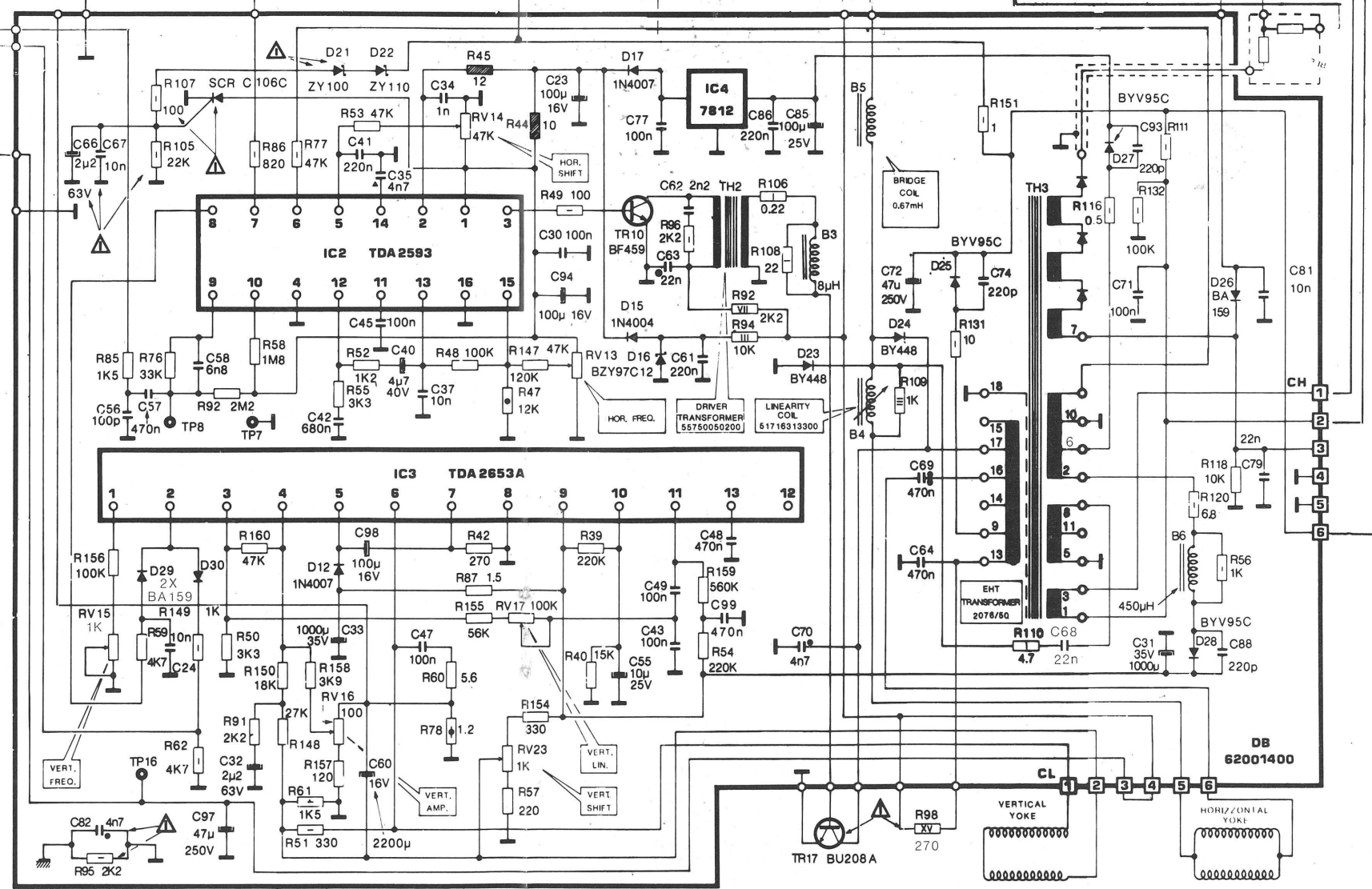
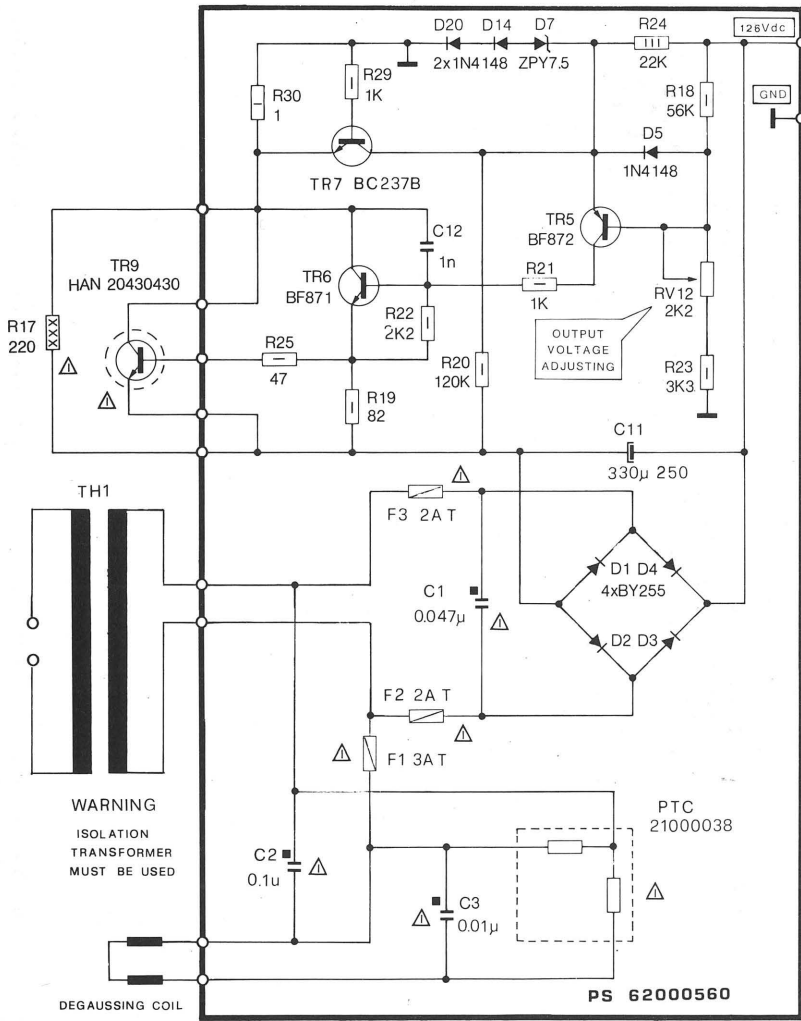
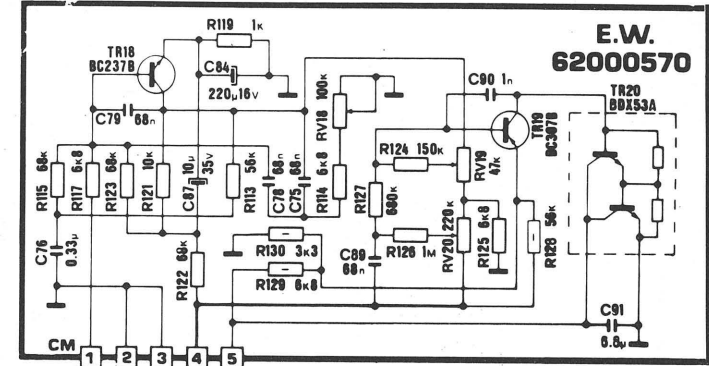
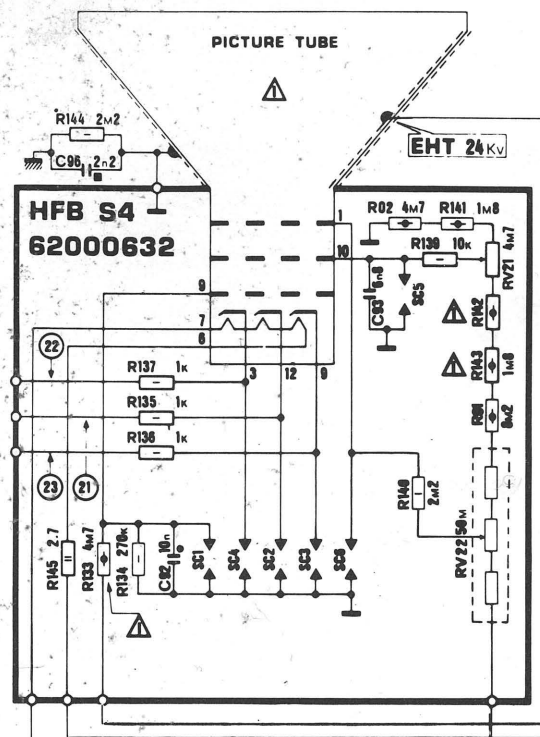
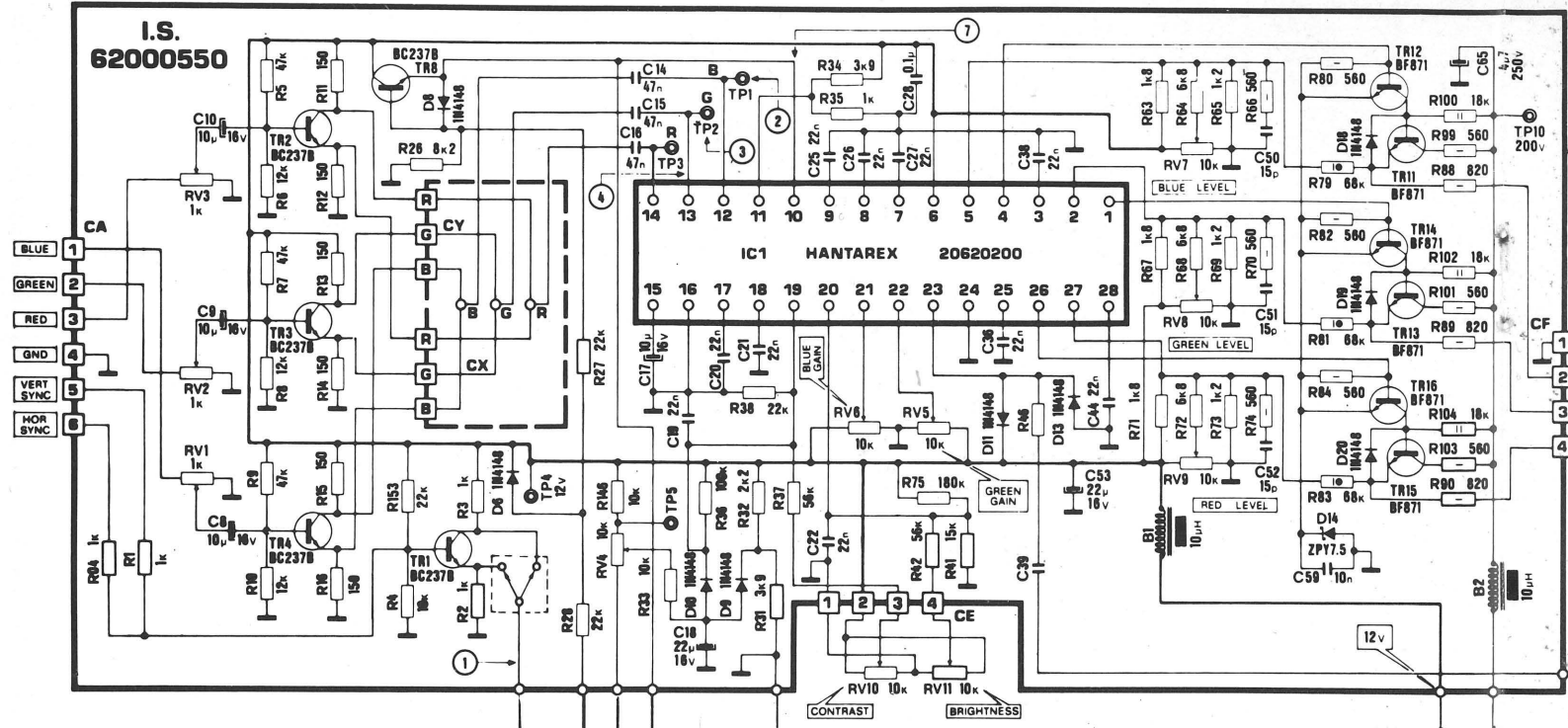

- TO 3
- TO 220
- TO 92
- 1/4W 1/2W 1W 2W
- 3W 7W 15W 30W
- RESISTOR 1/4 2%
- HIGH INSULATION RESISTOR 1/2W 2%
- RESISTOR 1W 2%
- RESISTOR 1/2W NON FLAMMABLE
- CAPACITOR 2.5%
- POLYPROPYLENE CAPACITOR
- DOUBLE METALLIZED POLYPROPYLENE CAPACITOR
- METALLIZED POLYESTER CAPACITOR REQUIRED BY VDE 0560-7
- INDICATES TEST POINT CONNEXION
- INDICATED CHASSIS GROUND
- FOR SAFETY PURPOSES (AND CONTINUING RELIABILITY) REPLACE ALL COMPONENTS MARKED WITH SAFETY SYMBOL WITH IDENTICAL TYPE
- SCOPE WAVEFORM REFER TO PAGE NUMBER

WAVEFORMS

Waveforms the diagram with reticular generator (white 100%) with the contrast at the most and medium brightness.

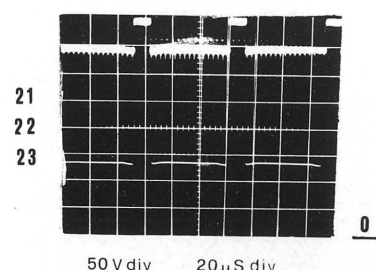
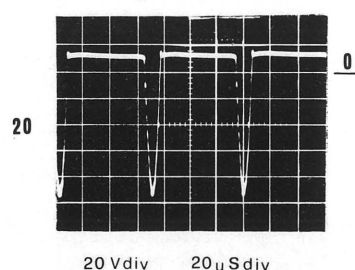
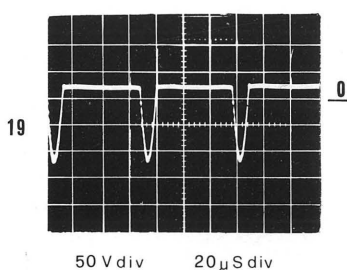
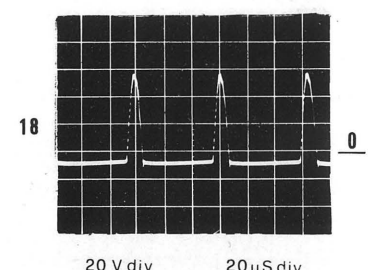
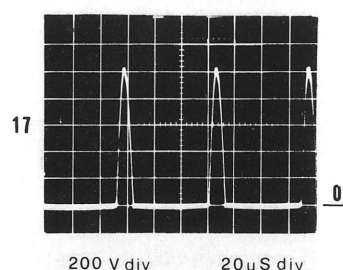
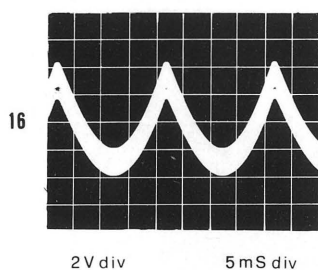
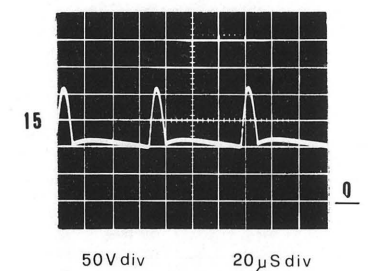
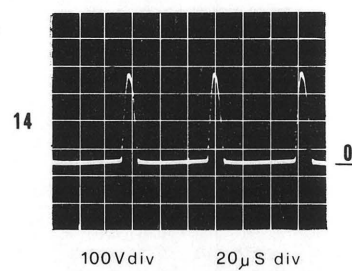
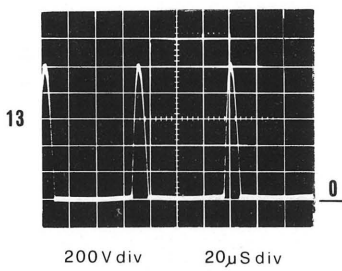
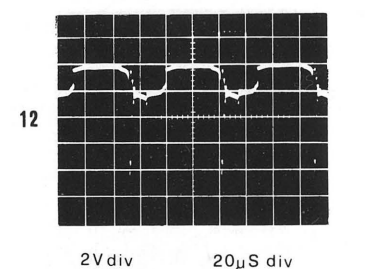
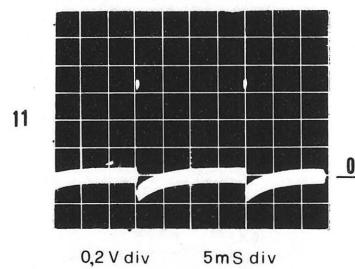
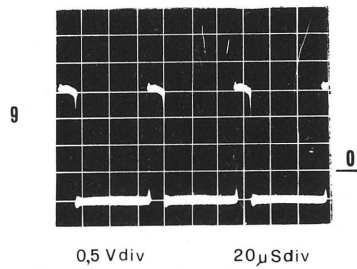
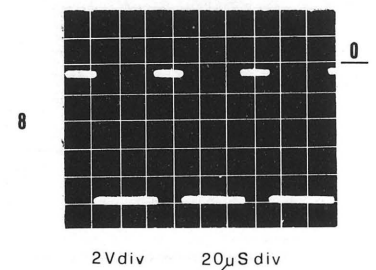
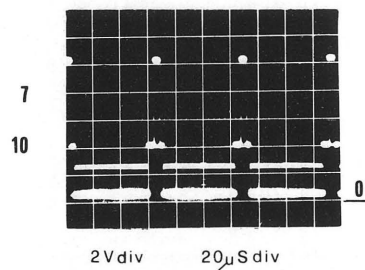
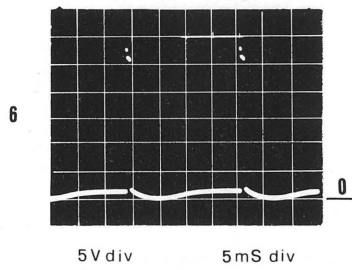
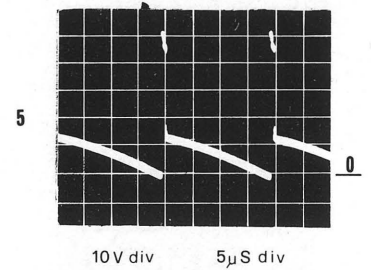
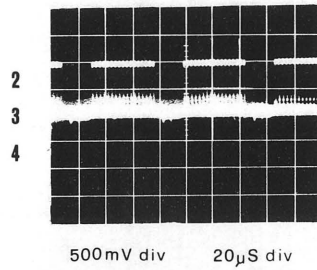
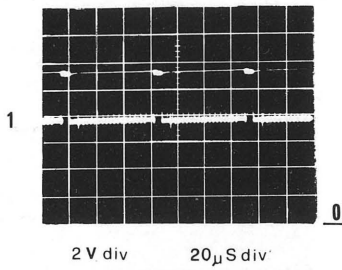

1. **INSTRUMENTACION NECESARIA** - Multímetro digital con impedancia de ingreso de 10 M Ω , osciloscopio con banda pasante de 10 MHz/seg. y sonda atenuadora 10/1.
Generador de barras RGB tipo HANTAREX mod. KG 159 o bien generador de barras B/N conectado a los ingresos 1, 2, 3 del conector CA en paralelo.
Después de tener encendido el monitor por aproximadamente 5 minutos, regular los mandos hasta obtener una imagen aceptable y proceder a continuación al ajuste de la platina según instrucciones abajo indicadas.
2. **ALIMENTACION SIN SEÑAL** El trimmer RV12 que regula la tensión de alimentación necesita una regulación solo para una eventual reparación, en tal caso proceder como sigue:
 - a) asegurarse que la tensión alterna de ingreso a los terminales 1 y 2 del conector CB, esté comprendida entre 120 y 135 V. CA
 - b) poner los controles del contraste y luminosidad al mínimo
 - c) conectar un voltímetro digital al TP16 y regular RV12 para una tensión de 126 V. CCATENCIÓN: tensiones superiores o inferiores a la nominal perjudican el buen funcionamiento del monitor.
3. **NIVELES DE INGRESO RGB** (señales barra color). Posicionar el conector CX para obtener sobre TP1, TP2, TP3, una señal video positiva. Regular la señal de ingreso de AZUL, mediante RV1, la señal del VERDE mediante RV2, la señal del ROJO mediante RV3 hasta obtener respectivamente sobre TP1, TP2, TP3 una amplitud igual a $1V_{pp} \pm 5\%$
4. **FINALES RGB** (Señal: barras color) desenchufar el zócalo del tubo. Regular RV9 para el ROJO, RV8 para el VERDE, RV7 para el AZUL para obtener sobre los respectivos TP14, TP13, TP12, las desconexiones horizontales a 160V. respecto del nivel de Occ (ver figura X pag. Y).
Amplitud de señal: posicionar el contraste y la luminosidad para tener sobre el cátodo del rojo TP14, 60 Vpp desde el nivel del negro al nivel del blanco. Regular RV6 para el verde y RV5 para el azul, hasta obtener sobre los respectivos TP12 y TP13 60 Vpp. Enchufar el zócalo del tubo.
5. **INTERDICCION DEL TUBO** (Señal: barras color). Posicionar los mandos de contraste y luminosidad hacia los mínimos de manera que se obtenga sobre el cátodo del Verde TP13 el nivel del blanco igual a 140 V desde Occ. Regular la rejilla aceleradora G2 por medio de R12 hasta el punto de interdicción del tubo.
6. **NIVELACION DEL BLANCO** (sin señal). En las mismas condiciones de medida del punto 5 aumentar la luminosidad hasta hacer visible el campo blanco.
Observar el eventual color dominante y reducirlo, a continuación aumentar los restantes colores para obtener una justa tonalidad del gris. Accionar por medio de RV7 para el Azul, RV8 para el Verde y RV9 para el Rojo. Repetir la operación del punto 5 debido a que puede haber tenido modificaciones.
7. **OSCILADOR HORIZONTAL** (Señal: retículo). cortocircuitar TP8 con TP7, regular RV13 para tener una imagen lo más fija posible en sentido horizontal, quitar a continuación el cortocircuito.
8. **OSCILADOR VERTICAL** (Señal: retículo). Cortocircuitar TP7 con TP8. Regular RV13 para tener un ligero corrimiento de la imagen hacia lo alto, quitar a continuación el cortocircuito.
9. **GEOMETRIA HORIZONTAL** (Señal: retículo). Regular RV20 para tener una justa amplitud horizontal, regular RV19 y RV18 (coorección cojín) para obtener derechas las líneas verticales a la extremidad derecha a izquierda del cuadro. Posicionar la bobina de linearidad horizontal B4 para la máxima amplitud, regular a continuación para la mejor linearidad horizontal. Regular RV14 para un correcto centraje en sentido horizontal, retocar eventualmente la amplitud horizontal por medio de RV20.
10. **GEOMETRIA VERTICAL** (Señal: retículo). Regular RV16 hasta disminuir la imagen aproximadamente 3 cm. respecto a las dimensiones del tubo. Centrar el retículo en el sentido vertical con RV18, regular de nuevo RV16 para una justa amplitud vertical y RV17 para la mejor linearidad (equidistancia de los cuadrados del retículo en el sentido vertical).
11. **LIMITACION DE LA CORRIENTE MEDIA DE HAZ** (Señal: barras color). Posicionar el contraste y la luminosidad al máximo y regular RV4 hasta obtener en TP4 y TP5 una tensión de $10,25 V \pm 0,25$ correspondiente a una corriente de haz de aproximadamente 1 mA.
12. **DESMAGNETIZACION** (Señal retículo). En el caso que la imagen del retículo resulta coloreada en alguna zona de la superficie del tubo, pulsar durante 2, 3 seg. el botón de desmagnetización.

MECHANICAL DATA

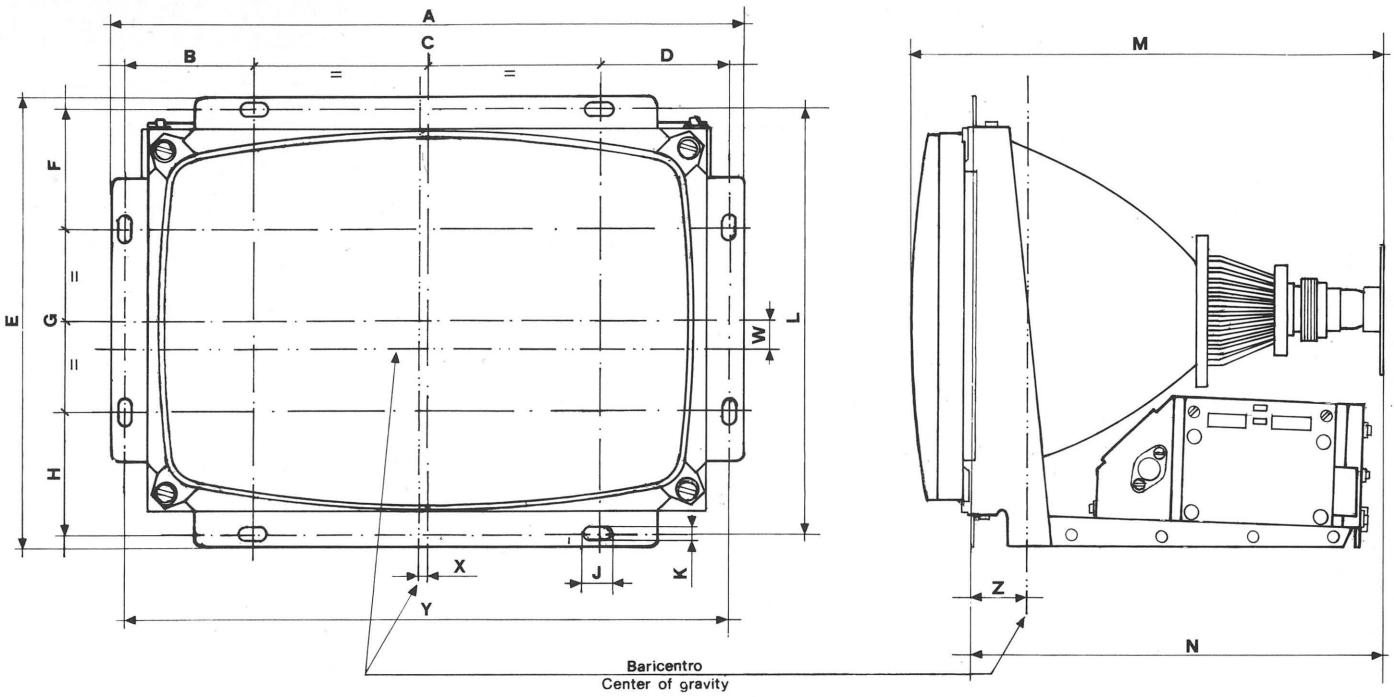

DIM.	A	B	C	D	E	F	G	H	J	K	L	M	N	W	X	Y	Z
14" mm	372	78	198	78	300	78	144	78	20	8	284	331	271	23	6	356	60
16" mm	424	78	250	78	347	78	175	78	20	8	331	363	310	32	6	408	47
14" IN.	14.646	3.071	7.795	3.071	11.811	3.071	5.669	3.071	0.787	0.315	11.181	13.031	10.669	0.905	0.236	14.016	2.362
16" IN.	16.693	3.071	9.842	3.071	13.661	3.071	6.89	3.071	0.787	0.315	13.031	14.291	12.205	1.26	0.236	16.063	1.85

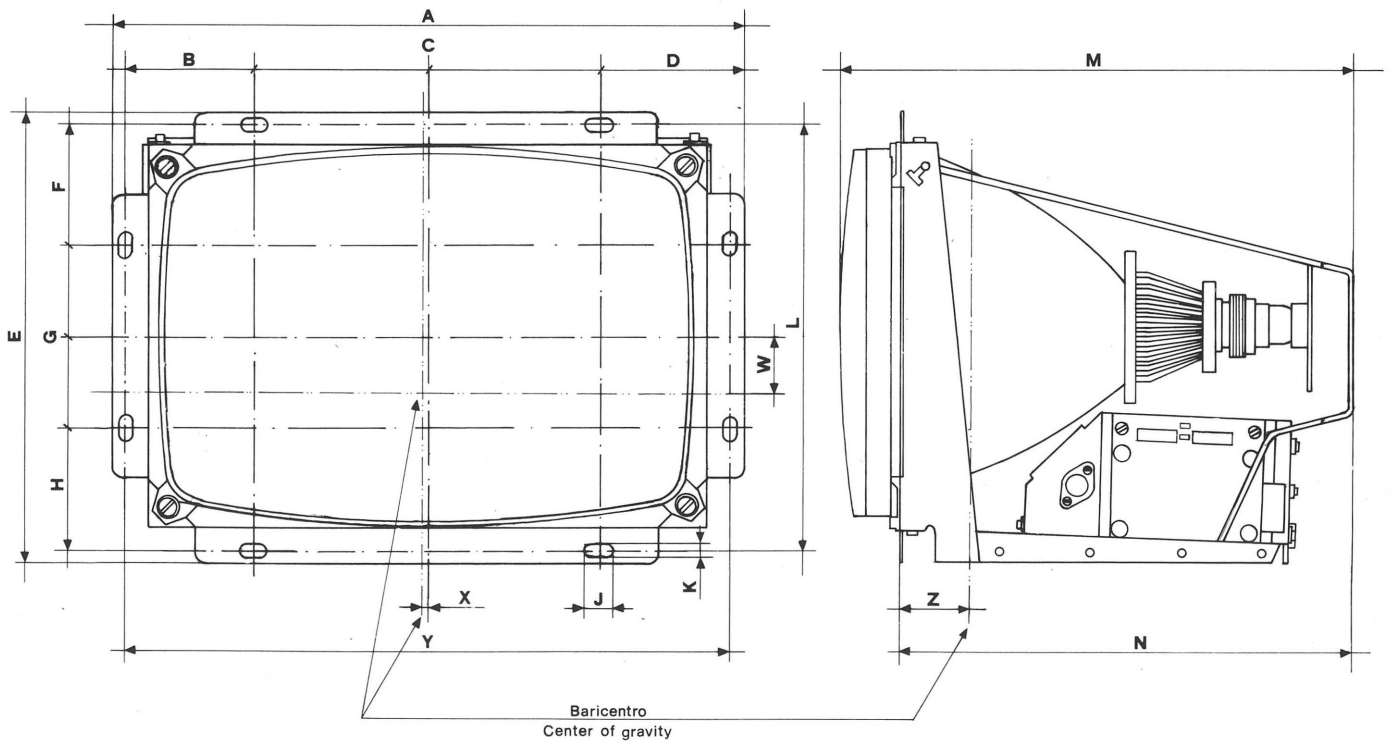

DIM.	A	B	C	D	E	F	G	H	J	K	L	M	N	W	X	Y	Z
20" mm	512	108	280	108	412	98	200	98	20	8	396	442	387	34	3	496	43
20" IN.	20.157	4.252	11.024	4.252	16.22	3.858	7.874	3.858	0.787	0.315	15.59	17.402	15.236	1.339	1.181	19.527	1.693

DB DEFLEXION cod. 62001401

CODICE	DESCRIZIONE COMPONENTE	RIF. SCHEMA	Q.TA
18016000	cabl. filo unip. 0,35 cm 6 + AMP		1
20100010	diode BA 159	D 26-29-30	3
20110100	diode zener 1,3 W BZY 97 C 12	D 16	1
20110300	diode zener 1,3 W ZY 100	D 21	1
20110500	diode zener 1,3 W ZPY 110	D 22	1
20150004	diode 1N 4004	D 15-17	2
20150007	diode 1N 4007	D 12	1
20150170	diode BYV 95/C-600	D 25-27-28	3
20150200	diode BY 448	D 23-24	2
20420110	trans. BF 459	TR 10	1
20440000	tiristore C 106 C	SCR	1
20620190	circ. int. TDA 2598	TC 2	1
21235600	res. 1/4 W 5% 5,6	R 60	1
21231200	res. 1/4 W 5% 120 E	R 157	1
21232200	res. 1/4 W 5% 220 E	R 57	1
21232700	res. 1/4 W 5% 270 E	R 42	1
21233300	res. 1/4 W 5% 330 E	R 154	1
21241200	res. 1/4 W 5% 1,2 K	R 52	1
21241500	res. 1/4 W 5% 1,5 K	R 85	1
21242200	res. 1/4 W 5% 2,2 K	R 91	1
21243300	res. 1/4 W 5% 3,3 K	R 50-55	2
21243900	res. 1/4 W 5% 3,9 K	R 58	1
21244700	res. 1/4 W 5% 4,7 K	R 59	1
21251200	res. 1/4 W 5% 12 K	R 40	1
21251201	res. str. met. 1/4 W 2% 12K PH.MR 25	47	1
21251800	res. 1/4 W 5% 18 K	R 150	1
21252700	res. 1/4 W 5% 27 K	R 148	1
21253300	res. 1/4 W 5% 33 K	R 76	1
21254700	res. 1/4 W 5% 47 K	R 53-160	2
21255600	res. 1/4 W 5% 56 K	R 155	1
21258200	res. 1/4 W 5% 82 K	156	1
21261000	res. 1/4 W 5% 100 K	R 48	1
21261200	res. 1/4 W 5% 120 K	R 147	1
21262200	res. 1/4 W 5% 220 K	R 39-54	2
21265600	res. 1/4 W 5% 560 K	R 159	1
21271800	res. 1/4 W 5% 1,8 M	R 58	1
21272200	res. 1/4 W 5% 2,2 M	R 92	1
21310500	res. 1/2 W 5% 0,5 E	R 116	1
21311000	res. 1/2 W 5% 1 E	R 151	1
21311201	res. str. met. 1/2 W 2% 1,2E PHVR37	R 78	1
21316800	res. 1/2 W 5% 6,8 E	R 120	1
21321000	res. 1/2 W 5% 10 E	R 44-131	2
21321200	res. 1/2 W 5% 12 E	R 45	1
21331000	res. 1/2 W 5% 100 E	R 49-86	2
21333300	res. 1/2 W 5% 330 E	R 51	1
21338200	res. 1/2 W 5% 820 E	R 105	1
21341000	res. 1/2 W 5% 1 K	R 149	1
21342200	res. 1/2 W 5% 2,2 K	R 96	1
21344700	res. 1/2 W 5% 4,7 K	R 62	1
21351000	res. 1/2 W 5% 10 K	R 118	1
21352200	res. 1/2 W 5% 22 K	R 107	1
21354700	res. 1/2 W 5% 47 K	R 77	1
21361000	res. 1/2 W 5% 100 K	R 111-132	1
21372200	res. 1/2 W 5% 2,2 M	R 95	1
21410220	res. 1 W 10% 0,22 E VTM 200-0	R 106	1
21411500	res. 1 W 5% 1,5 E	R 87	1
21414700	res. 1 W 5% 4,7 E resista WK 4	R 110	1
21422200	res. 1 W 5% 2,2 E	R 108	1
21441000	res. 1 W 5% 1 K	R 56	1
21641000	res. 3 W 5% 1 K resista WK8	R 109	1
21651000	res. ossido met. 3 W 5% 10 K	R 94	1
22342200	res. a filo ass. 7 W 5% 2,2 K	R 97	1
23031000	trimmer PT 10 H 100 E	RV 16	1
23041000	trimmer vert. PT 15 NH 1 K	RV 23	1
23054703	trimmer vert. PT 15 NH 47 K	RV 13-14	2
23061002	trimmer vert. PT 10 H 100 K	RV 17	1
23062201	trimmer vert. PT 14 NH 220 K	RV 15	1
24314700	cond. el. EN 12,35 4,7 MF 16 V	C 40	1
24331000	cond. el. EN 12,35 100 MF 16 V	C 23-94-98	3
24342200	cond. el. EN 12,35 2200 MF 16 V	C 60	1
24421000	cond. el. EN 12,35 10 MF 25 V	C 55	1
24431000	cond. el. EN 12,35 100 MF 25 V	C 85	1
24541000	cond. el. EN 12,35 1000 MF 35 V	C 31-33	2
24612200	cond. el. EN 12,35 2,2 MF 63 V	C 32-66	2
24924702	cond. el. EN 12,35 47 MF 250 V	C 72-97	2
25144701	C P 4N7 PF 2,5% 63 V 1,42 P 7,2	C 35	1
25262200	C P 220 NF 10% 100 V 1,60 P 10	C 41-61-86	3
25264700	C P 470 NF 10% 100 V 1,60 P 15	C 48-57-99	3
25266800	C P 680 NF 10% 100 V 1,60 P 15	C 42	1
25361000	C P 100 NF 20% 160 V 1,60 P 10	C 43-45-47-49-81	5
25452201	C P 22 NF 10% 250 V 1,73 P 15	C 79	1
25461000	C P 100 NF 10% 250 V 1,60 P 15	C 71	1
25464700	C P 470 NF 10% 250 V 1,60 P 22,5	C 64	1
25464710	C P 470 NF 10% 250 V 1,76 P 22,5	C 69	1
25552200	C P 22 NF 10% 400 V 1,60 P 10	C 63	1
25646800	C P 6N8 PF 10% 630 V 1,60 P 10	C 58	1
25651000	C P 10 NF 10% 630 V 1,60 P 10	C 24-37	2
25741000	C P 1 NF 10% 1000 V 1,60 P 10	C 34	1
25744705	C P 4N7 PF 10% 1500 V 1,73 P 15	C 82	1
25752201	C P 22 NF 10% 1000 V 1,73 P 22,5	C 68	1
25944700	C P 4N7 PF 5% 1750 V 1,73 P 22,5	C 70	1
26310100	C C 100 PF 5% 50 V NPO	C 56	1
26322720	C C 220 PF 20% 2000 V 507,1	C 74-88-93	3
26422608	C C 2200 PF 20 + 50 500 V 511,1	C 62	1
26610601	C C 100000 PF 20 + 80 50 V	C 30-77-67	3
28010080	trasf. pilota MTC 90 PL. 55750050200	TH 2	1
28010160	trasf. diode split 2076-50	TH 3	1
28020200	bobina choker 8 MH su ferrite	B 3	1
28020300	bobina choker 450 MH su ferrite	B 6	1
28040020	bobina linearita ples. 51716313300	B 4	1
28070060	bobina bridg 0,67 MH	B 5	1

34020090	zoccolo C.I. 16 PIN		1
34023306	connett amp. mod. I - 6 90-280617/1	CH	1
34023356	connettore amp. mod. I - 6 D 280611/1	CL	1
38000000	cavetto split blider 167 M		1
41000003	dado ferro 3 MA H=1 tornito		2
42000070	rondella elastica 3,2 x 6		2
50110800	staffa metallica sostegno trasf.		1
50142800	circ. stampato defles. MTC900 DB		1
50420220	alberini trimmer 6 L=12		4
62000570	ass. C.S.E-W MTC 900		1
62001390	ass. dissipatore TDA 2653 A		1

EW East-West code 62000570

CODE	DESCRIPTION	REF. NO.	QTY.
20400420	trans. BC 237 B	TR 18	1
20400402	trans. BC 307 B	TR 19	1
20401010	trans. BDx 53 A	TR 20	1
21241000	res. 1/4 W 5% 1 K	R 119	1
21246800	res. 1/4 W 5% 6 K 8	R 114-R 117-R 125	3
21251000	res. 1/4 W 5% 10 K	R 121	1
21255600	res. 1/4 W 5% 56 K	R 113	1
21255800	res. 1/4 W 5% 68 K	R 115-R 122-R 123	3
21261500	res. 1/4 W 5% 150 K	R 124	1
21266800	res. 1/4 W 5% 680 K	R 127	1
21271000	res. 1/4 W 5% 1 M	R 126	1
21343300	res. 1/2 W 5% 3 K 3	R 130	1
21346800	res. 1/2 W 5% 6 K 8	R 129	1
21355600	res. 1/2 W 5% 56 K	R 128	1
23054702	vertical trimmer PT 10 H 47 K	RV 19	1
23061002	vertical trimmer PT 10 H 100 K	RV 18	1
23062202	vertical trimmer PT 10 H 220 K	RV 20	1
24332200	electrolytic capacitor EN 12,35 220 µF 16 V	C 84	1
24521000	electrolytic capacitor EN 12,35 10 µF 35 V	C 87	1
25363300	polyester capacitor 0,33 µF 20% 160 V 1,60	C 76	1
25266800	polyester capacitor 6,8 µF 10% 100 V 1,60	C 91	1
25456800	polyester capacitor 68 µF 10% 250 V 1,60	C 75-C 78-C 79-C 89	4
25741000	polyester capacitor 1 nF 10% 1000 V 1,60	C 90	1
34021305	connector 6630/5 D	—	1
50110440	U-heat sink	—	1
50142250	EW MTC 900 printed circuit	—	1
40003010	screws 3 MA x 10 TCC	—	1
41000003	turned nut 3 MA H = 1	—	1
42000000	locking washer 3,2 x 6,3 x 0,4 AZ	—	1

PS Power unit code 62000560

CODE	DESCRIPTION	REF. NO.	QTY.
20100000	diode 1N 4148	D 5	1
20150130	diode BY 255	D 1-D 2-D 3-D 4	4
20670010	int. cct. ZTK 9	D 7	1
20400420	trans. BC 237 B	TR 7	1
20420510	trans. BF 872	TR 5	1
20420500	trans. BF 871	TR 6	1
21328200	res. 1/2 W 5% 82 Ω	R 19	1
21341000	res. 1/2 W 5% 1 K	R 21-R 29	2
21342200	res. 1/2 W 5% 2 K 2	R 22	1
21355600	res. 1/2 W 5% 56 K	R 18	1
21361200	res. 1/2 W 5% 120 K	R 20	1
21411000	res. 1 W 5% 1 Ω resista WK 4	1	1
21652200	res. 3 W 5% 22 K resista WK 8	R 24	1
21343300	res. 1/2 W 5% 3 K 3	R 23	1
21324700	res. 1/2 W 5% 47 Ω	R 25	1
24933301	electrolytic capacitor EN 12,12 330 µF 250 V	C 11	1
23042201	vertical trimmer PT 15 H 2 K 2	RV 12	1
25761002	polyester capacitor 0,1 µF 10% 250 Vac 1,58	C 2	1
25754701	polyester capacitor 47 nF 10% 250 Vac 1,58	C 1	1
25751002	polyester capacitor 10 nF 10% 250 Vac 1,58	C 3	1
26410803	ceramic capacitor 1000 pF 10% 50 V	C 12	1
26422608	ceramic capacitor 2200 pF —20 + 50 500 V 511,1	C 4-C 5-C 6-C 7	4
21000037	dual PTC thermistor 2322.662.98009	PTC	1
29100050	fuse holder for printed circuit NUVAl 28011	—	3
29100000	fuse 2 AT	1-F 2-F 3	3
34023304	AMP connector MOD 1 4 way 10-280616/1	—	1
34023352	AMP connector MOD 1 2 way D 280609/1	—	2
34020004	AMP faston connector M. 735084/2	—	8
61000300	degaussing link assembly	—	1

PARTS LIST

IS Interface code 62000550

CODE	DESCRIPTION	REF. NO.	QTY.
20100000	diode 1N 4148	D 6-D 8-D 9-D 10-D 11-D 13-D 18-D 19-D 20	9
20110200	zener diode 1,3 W ZY 7,5	D 14	1
20400420	trans. BC 237 B	TR 1-TR 2-TR 3-TR 4-TR 8	5
20420500	trans. BF 871	TR 11-TR 12-TR 13-TR 14	6
20620200	int. cct. HANTAREX	TR 15-TR 16	1
21241000	res. 1/4 W 5% 1 K	IC 1	1
21241200	res. 1/4 W 5% 1 K 2	R 1-R 2-R 3-R 4-R 35-R 04	6
21242200	res. 1/4 W 5% 2 K 2	R 65-R 69-R 73	3
21243900	res. 1/4 W 5% 3 K 9	R 32	2
21246800	res. 1/4 W 5% 6 K 8	R 31-R 34	1
21248200	res. 1/4 W 5% 8 K 2	R 64-R 68-R 72	3
21251000	res. 1/4 W 5% 10 K	R 26	1
21251200	res. 1/4 W 5% 12 K	R 4-R 28-R 33-R 146	4
21251500	res. 1/4 W 5% 15 K	R 6-R 8-R 10	3
21252200	res. 1/4 W 5% 22 K	R 41	1
21254700	res. 1/4 W 5% 47 K	R 27-R 28-R 153	3
21255600	res. 1/4 W 5% 56 K	R 5-R 7-R 9	3
21261000	res. 1/4 W 5% 100 K	R 37-R 42	2
21261800	res. 1/4 W 5% 180 K	R 36	1
21335600	res. 1/4 W 5% 560 Ω	R 75	1
21338200	res. 1/2 W 5% 820 Ω	R 66-R 70-R 74-R 80-R 82-R 84-R 99-R 101-R 103	9
21241800	res. 1/4 W 5% 1 K 8	R 88-R 89-R 90	3
21231500	res. 1/4 W 5% 150 Ω	R 36-R 37-R 71	3
21456801	metal film resistor 1 W 2% 68 K resista WK 4	R 11-R 12-R 13-R 14-R 15-R 16	6
21551800	res. 2 W 5% 18 K resista WK 5	R 79-R 81-R 83	3
23051001	horizontal trimmer PT 10 V 10 K	R 100-R 102-R 104	3
23041003	vertical trimmer PT 10 H 1K	RV 4-RV 5-RV 6-RV 7-RV 8-RV 9	6
24321000	electrolytic capacitor EN 12.35 10 μF 16 V	RV 1-RV 2-RV 3	3
24322200	electrolytic capacitor EN 12.35 22 μF 16 V	C 8-C 9-C 10-C 17	4
24914700	electrolytic capacitor EN 12.35 4,7 μF 250 V	C 18-C 53	2
25552200	polyester capacitor 22 nF 10% 400 V 1.60	C 65	1
25454700	polyester capacitor 47 nF 10% 250 V 1.60	C 19-C 20-C 21-C 22-C 25-C 26-C 27-C 36-C 38-C 44	10
26215100	ceramic capacitor 15 pF 5% 50 V NPO	C 14-C 15-C 16	3
26610601	ceramic capacitor 0,1 μF -20+80 50 V	C 50-C 51-C 52	3
26510601	ceramic capacitor 10 nF -20+80 50 V	C 28	1
28020130	choke 10 mH	C 59	1
34020200	socket int. cct. 28 pin	B 1-B 2	2
34023354	AMP connector MOD I 4 way 280610/1	—	1
34023306	AMP connector MOD I 6 way 280617/1	—	2
50142230	interface printed circuit MTC 900	—	1
29300010	ferric beads 8 mm	—	12
34020000	terminal PE 1120/D	—	8
34020007	terminal for printed circuit AMP 280644/2	—	2
61000210	AMP CIS connector cable assembly	—	1
34023604	AMP CIS connector 4 way 163680/2	CX-CY	2

FB C.R.T. Base code 62000630

CODE	DESCRIPTION	REF. NO.	QTY.
21341000	res. 1/2 W 5% 1 K	R 135-R 136-R 137	3
21351000	res. 1/2 W 5% 10 K	R 139	1
21362700	res. 1/2 W 5% 270 K	R 134	1
21371801	metal film resistor 1/2 W 2% 1 M 8 PHVR 37	R 141-R 142-R 143	3
21374701	metal film resistor 1/2 W 2% 4 M 7 PHVR 37	R 133	1
21472200	res. 1 W 5% 2 M 2	R 140	1
21512700	res. 2 W 5% 2,7 Ω resista WK 5	R 145	1
23074700	horizontal trimmer PT 15 V 4 M 7	RV 21	1
23800020	focus potentiometer 50 M Ω RVF 0615	RV 22	1
25751000	polyester capacitor 10 nF 10% 1000 V 1.73	C 92	1
26468720	ceramic capacitor 6,8 nF 20% 2000 V 507.6	C 93	1
29041000	spark gap 1 KV 14/1-003-KA 2	SC 1-SC 2-SC 3-SC 4-SC 5	5
29048500	spark gap 8,5 KV 14/1-0,17-01	SC 6	1
34020020	c.r.t. base 20" 90 CN 55	—	1
50142260	FB c.r.t. p.c.b. MTC 900	—	1
61000110	c.r.t. base cable assembly MTC 900	—	1
61000100	R.G.B. cable assembly MTC 900	—	1
61000150	wire ground picture tube cable assembly	—	1
29300010	ferric beads 8 mm	—	2
34020000	terminal PE 1120/D	TP 12-TP 13-TP 14	3

MTC 900 Aluminium Heat Sink Assembly code 62000600

CODE	DESCRIPTION	REF. NO.	QTY.
50110530	aluminium heat sink	—	1
62000590	potentiometer mount assembly	—	1
40035065	self tapping screw 3,5×6,5 TCC	—	2
34020060	socket for transistor TO 3	—	1
50420120	mica insulator for TO 3 500 V	—	1
22932200	axial wirewound 30 W resistor 10% 220 Ω	R 17	1
50420170	FASTEX plastic spacer 37-0285-9200	—	5
40029065	self tapping screw 2,9×6,5 TCC	—	4
40035013	self tapping screw 3,5×13 TCC	—	2
42000020	GROVER washer 4,3×1,5×0,9	—	2
62000560	MTC 900 Power Unit printed circuit assembly	—	1
20430430	trans. HAN 20430430	TR 9	1
16321000	3 wires 100 mm	—	1
16019000	wire Ø 0,35 90 mm	—	1
16017000	wire Ø 0,35 70 mm	—	1
34020005	AMP Faston F 140717/2	—	1

MTC 900 Aluminium Heat Sink Assembly code 62000610

CODE	DESCRIPTION	REF. NO.	QTY.
50110550	heat sink	—	1
20430200	trans. BU 208 A	TR 17	1
50420180	mica insulator for TO 3 2000 V	—	1
34020060	socket for transistor TO 3	—	1
22622700	axial wirewound 15 W resistor 10% 27 Ω	R 98	1
40029065	self-tapping screw 2,9×6,5 TCC	—	3
50420170	FASTEX plastic spacer 37-0285-9200	—	1
42000020	GROVER washer 4,3×1,5×0,9	—	2
40035013	self tapping screw 3,5×13 TCC	—	2
16316000	3 wires 60 mm	—	1
16017000	wire Ø 0,35 70 mm	—	1
16012000	wire Ø 0,35 20 mm	—	1
50420090	cable clamp 20-0875-1100 103 mm	—	2

Potentiometer Mount code 62000590

CODE	DESCRIPTION	REF. NO.	QTY.
50110520	potentiometer mount support	—	1
23251000	potentiometer mount support	—	1
23251000	potentiometer P 160 CM 7 C 6 AXF 1-10 K-4×30	RV 10-RV 11	2
61000080	potentiometer cable assembly MTC 900	—	1
30000000	switch MIYAMA MS 030	—	1

MTC 900 Frame Assembly code 62000620

CODE	DESCRIPTION	REF. NO.	QTY.
50110560	front bracket	—	1
50110570	back bracket	—	1
50110580	centre bracket	—	1
62000610	aluminium heat sink assembly	—	1
62000600	aluminium heat sink assembly	—	1
40942095	self-tapping screw 4,2×9,5 TE bordino	—	8
62000580	deflexion printed circuit	—	1
62000550	interface printed circuit	—	1
40935065	self-tapping screw 3,5×6,5 TE bordino	—	11

Potentiometer Cable Assembly code 61000080

CODE	DESCRIPTION	REF. NO.	QTY.
34023404	MOD I AMP connector 4 way 280591	—	1
34020002	AMP conctat 280702/1	—	4
16431000	4 wire cm 100	—	1

MTC 900 CONNEXION DIAGRAM

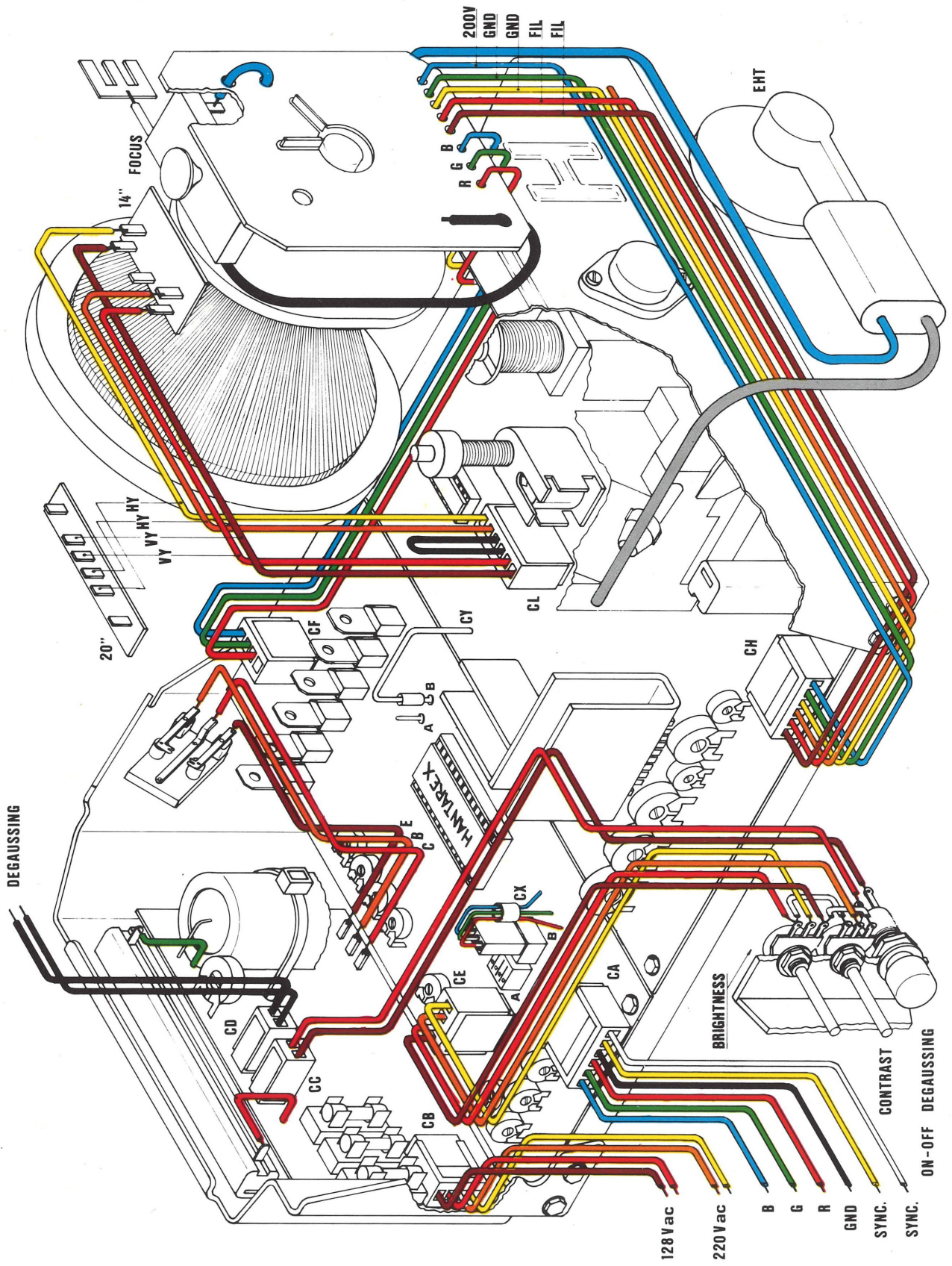

SUPPORT FOR CHASSIS ASSEMBLY

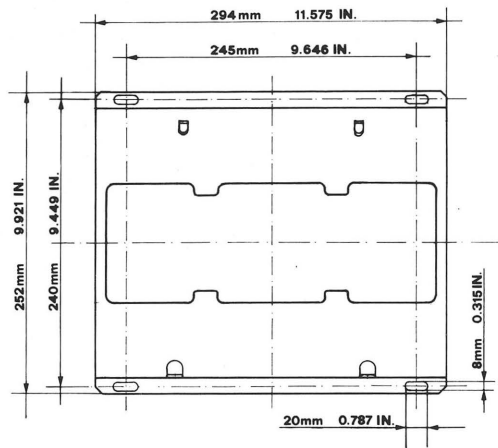

CHASSIS WITH SWITCH MODEL POWER SUPPLY INCORPORATED

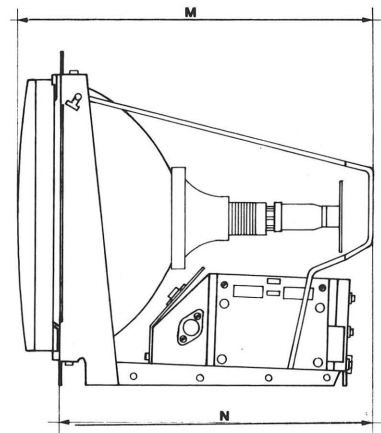
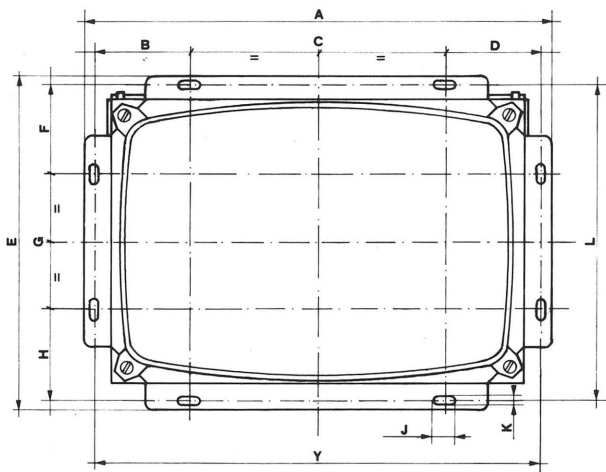
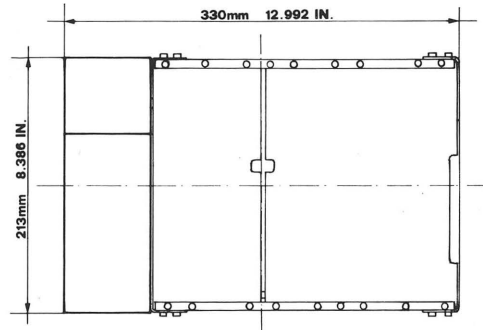

DIM.	A	B	C	D	E	F	G	H	J	K	L	M	N	Y
20" mm	512	107	282	107	410	97	200	97	20	8	394	450	385	496
22" mm	560	132	280	132	449	104	225	104	20	8	433	455	385	542
26" mm	636	170	280	170	500	109	271	109	20	8	489	475	385	620
20" IN.	20.157	4.213	11.102	4.213	16.142	3.819	7.874	3.819	0.787	0.315	15.512	17.716	15.157	19.527
22" IN.	22.047	5.197	11.024	5.197	17.677	4.094	8.858	4.094	0.787	0.315	17.047	17.913	15.157	21.338
26" IN.	25.039	6.693	11.024	6.693	19.694	4.291	10.669	4.291	0.787	0.315	19.252	18.701	15.157	24.409

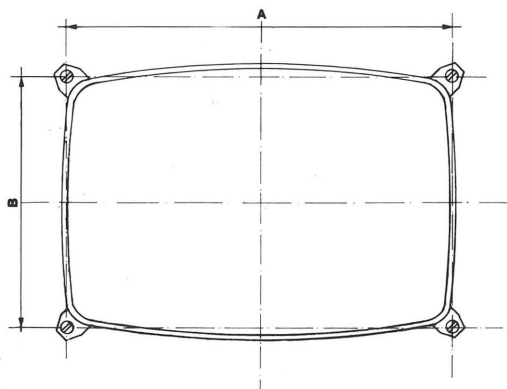

DIM.	A	B
20" mm	436	334
22" mm	470	359
26" mm	542	406
20" IN.	17.165	13.15
22" IN.	18.504	14.134
26" IN.	21.339	15.984

Technical Data

The MTC 900 is a colour monitor with high resolution, obtained by the coupling of a special cathode ray tube in which the triad of colour phosphors on the screen are spaced by only 0.31 mm (that is less than half the spacing on a standard c.r.t.), to an MTC 900 chassis with a special RGB video interface at TTL level capable of driving the cathode ray tube with rise and fall times of less than 20 n sec.

The result is the ability of the monitor clearly to display 2,000 colour characters, that is to say 80 characters in every 25 lines, a capacity equal to that currently only found in black and white monitors.

This product offers the latest advance in improving the display of colour images for computers and graphics display units.

Technical characteristics of the high resolution Colour data and graphics display monitor

Input signal:	Video input RGB TTL. vertical sync. TTL negative or positive horizontal sync TTL negative or positive
c.r.t.:	12" high resolution; triad spacing 0.31 mm. 14" high resolution; triad spacing 0.31 mm. 20" high resolution; triad spacing 0.31 mm.
Power required:	220Vac plus or minus 10%, 50-60 Hz
Power consumption:	as for MTC 900
Video amplifier:	rise and fall times 20n sec at 40 Vpp.
Horizontal sync:	15.625 + 0.5 k Hz
Vertical sync:	40 - 60 Hz
External controls:	contrast on-off
Internal controls:	as on MTC 900

Dati Tecnici

Il modello MTC 900 è un monitor a colori ad alta risoluzione ottenuta mediante l'accoppiamento di uno speciale tubo con le triadi di colore distanti 0,31 mm. (cioè meno della metà di un cinescopio standard) ed uno chassis della serie MTC 900 con speciale interfaccia video RGB a livello TTL capace di pilotare il cinescopio stesso con tempi di salita e discesa inferiore a 20 n. sec.

Il risultato è la capacità del monitor di rappresentare chiaramente a colori 2.000 caratteri, cioè 80 caratteri per 25 linee, capacità questa già limite in monitors bianco e nero.

Con questo prodotto si amplia ulteriormente la possibilità di visualizzare immagini a colori da calcolatori grafici.

Caratteristiche tecniche del DGD a colori H.R.

Segnale di ingresso:	ingresso video RGB TTL positiov sincr. vert. TTL negativo o positivo sincr. oriz. TTL negativo o positivo composito H + V negativo o positivo
Tubi impiegati:	12" H.R. distanza fra triodi 0,31 mm. 14" H.R. distanza fra triodi 0,31 mm. 20" H.R. distanza fra triodi 0,31 mm.
Alimentazione:	220 Vac. + 10% 60 ÷ 50 Hz
Potenza assorbita:	Wattaggio MTC 900
Amplificatore Video:	Tempo di salita e discesa 20 n sec. a 40 Vpp
Sincronizzatore H:	15750 + 0,5 KHz
Sincronizzatore V:	40 ÷ 60 Hz
Controllo esterno:	Contrasto ON-OFF Degaussing
Controlli interni:	come su MTC 900

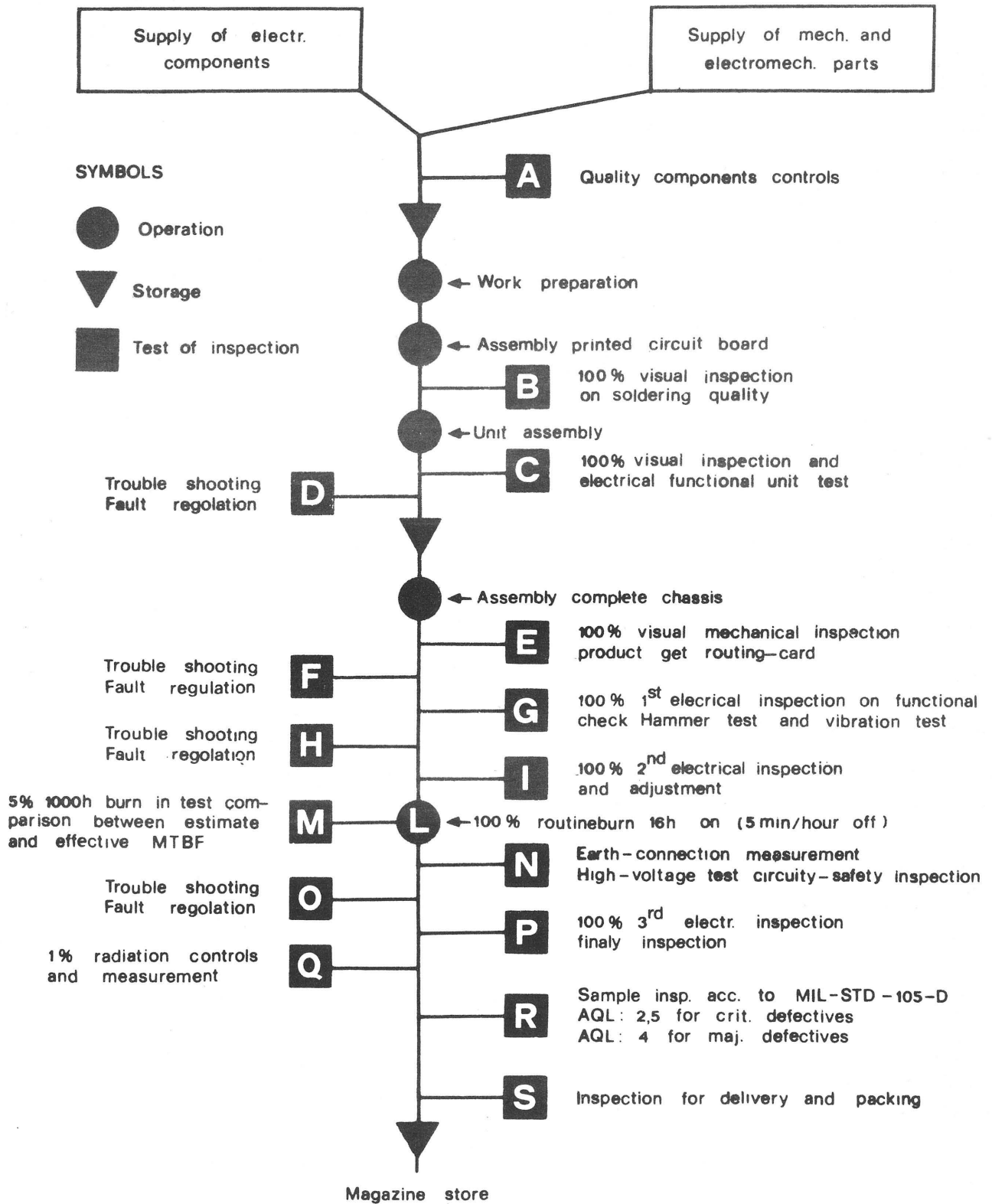

●●● tradition:

thirty years of constant development and diligent work, from black-white and colour television sets, to monitors for home and professional use: this is the record of a dynamic company keeping step with changing markets need.

TRADIZIONE: trent'anni di costante sviluppo ed assiduo lavoro, dai televisori in bianco-nero e colore, ai monitor civili e professionali: l'iter di un'industria dinamica, al passo con le esigenze del mercato.

●●● research:

all our technical laboratories work with the utmost dedications as they follow complete, precise programs in order to up-date and fine-tune our production line.

RICERCA: tutti i nostri laboratori tecnici operano con massimo impegno, secondo precisi e finalizzati programmi, per l'aggiornamento e la messa a punto della nostra produzione.

●●● quality:

our work tradition, on-going research and up-dating methods guarantee that our products are completely reliable and of high quality.

QUALITÀ: la nostra tradizione di lavoro, la costante ricerca e l'aggiornamento garantiscono la realizzazione di prodotti di completa affidabilità e qualità.

●●● progress:

our international organizational network ensures that we are dynamic and in step with the latest market demands, the needs of our sector, and our own production line.

PROGRESSO: la nostra rete di organizzazione, a livello internazionale, ci permette di essere tempestivamente aggiornati e dinamici di fronte alle sempre nuove richieste del mercato e alle problematiche del settore e della produzione.

●●● international:



HANTAREX SUD
01100 VITERBO - ITALY
str. Cassia Nord km. 88
tel. 0761/223241



HANTAREX ESPAÑOLA
210 Aragon str.
BARCELONA II - ESPAÑA
tel. 3232941 - telex 51189

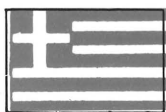

HANTAREX HELLAS
54, Gounari Str. - Sourmena
Glifada - ATHENS - GREECE
tel. 01/9913336
telex 219875 Anta-Gr



HANTAREX DEUTSCHLAND
Siegenerstrasse 23
5230 ALTENKIRCHEN - BRD
tel. 02681/3041-42
telex 869991 Hant X-D

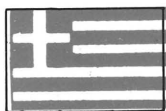

SELCON
35, Ippokratos Str. - Ellinikon
Glifada - ATHENS - GREECE
tel. 01/219875 Anta-Gr

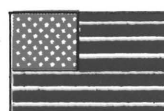

HANTAREX U.S.A.
127 Prospect Avenue
DOUGLASTON - New York 11363
tel. (212)423-2672/2915
telex 5200046



HANTAREX UNITED KINGDOM
95, Haymerle Road
LONDON SE15 6SA - ENGLAND
tel. 01/639-9343
telex 8952421 Hantar - G



HANTAREX JAPAN
Dai Nihon P.R. Centre BLDG
3-8 Irifune - 2 Chome
TOKIO 104 - JAPAN
tel. 03/4989343 - telex 28185



HANTAREX®

Electronic
Equipment
Manufacturer

50134 FIRENZE - Italy - 30. Via Riguccio Galluzzi - tel. 055/483176.7.8.9 - telex 572341 Hantar - I